

INSTRUCTION MANUAL



Model RAM Module Remote Sensor/Alarm Relay Module For use with Model 700 series sensors



◆ TELEDYNE DETCON, Inc.
4055 Technology Forest Blvd.,
The Woodlands, Texas 77381
Phone 713.559.9200

www.teledynegasandflamedetection.com

This page left intentionally blank

Table of Contents

1.	Introduction	1
1.1	Description	1
1.2	Installation	1
1.3	Field Wiring	4
2.	Operator Interface.....	7
3.	Set-up and Normal Operation.....	9
3.1	View Sensor Status	9
3.2	Set AutoSpan Level	10
3.3	Set Serial ID.....	10
3.4	Set-up for Relay Outputs	10
3.5	Signal Output Check	12
4.	RS-485 Modbus™ Protocol.....	13
5.	RAM Electronics Warranty.....	13
6.	Specifications	14
7.	Spare Parts	15
8.	Revision Log	16

Table of Figures

Figure 1	700 RAM	1
Figure 2	Mounting RAM with 700 Sensor.....	2
Figure 3	RAM Mounting.....	3
Figure 4	Exploded View of Assembly	3
Figure 5	Typical Installation	4
Figure 6	Interface connections on terminal board.....	5
Figure 7	Installation with 700 Gas Sensor	5
Figure 8	Remote 700 Gas Sensor with RAM.....	6
Figure 9	Remote Sensor Wiring	6
Figure 10	RAM Software Flowchart.....	8
Figure 11	RAM Label	15

This page left intentionally blank

1. Introduction

1.1 Description

The Model 700 Remote Sensor/Alarm Relay Module (known as the Remote Alarm Module or RAM) is sold separately as an accessory for Model 700 Gas Sensors. It is a universal design and can be used with any of the Model 700 Gas Sensors. The RAM is provided in an explosion-proof junction box constructed of either epoxy-painted aluminum (Figure 1) or 316 stainless steel and includes a glass-viewing window.



Figure 1 700 RAM

The RAM performs two main functions. The first function is to set gas alarm levels and to configure the three local relay contacts. The second function is to operate a Model 700 Gas Sensor remotely. The remote sensor function is typically used when the sensor must be mounted in a position where it cannot be viewed or accessed readily. Both functions can be used at the same time.

The RAM provides the 4-20mA output directly from the Model 700 Gas Sensor. The RAM acts as a Modbus™ master to the Model 700 Gas Sensor in order to display the reading and execute the remote control functions. It acts as a Modbus™ slave to any master control device and simply repeats the Modbus™ output from the 700 Gas Sensor it is connected to.

1.2 Installation

The RAM can be installed as a wall mount or pipe mount using the mounting holes of the explosion-proof junction box. It should be oriented such that the LED display is horizontal. If the 700 Gas Sensor is mounted directly to the RAM, use 0.5” spacers underneath the mounting holes to provide access clearance for the 700 Gas Sensor (Figure 2).

NOTE: Block any unused 3/4” NPT holes with the proper Plug. (Teledyne Detcon P/N 8522-750)

NOTE: Install only where the ambient temperature at place of installation is within the rated temperature limits of this device (-40°C to +70°C).

NOTE: All devices connecting to the 3/4” NPT conduit entries should be tightened to a minimum of 16 Foot-Pounds torque.

NOTE: The flamepath joints are not intended to be repaired if damaged.

NOTE: For ATEX use, cable glands, adapters, and/or blanking elements shall be ATEX certified to Ex d IIC and shall be installed.

WARNING: Cables and cable glands must be rated for $\geq 90^{\circ}\text{C}$.

NOTE: Use internal and external grounding points as required or recommended by electrical installation guidelines. Tighten to full hand-tight or 12 Foot-Lbs torque.

NOTE: Connect earth wire to crimped terminal ($\geq 4\text{mm}^2$) (Internal and external ground points)

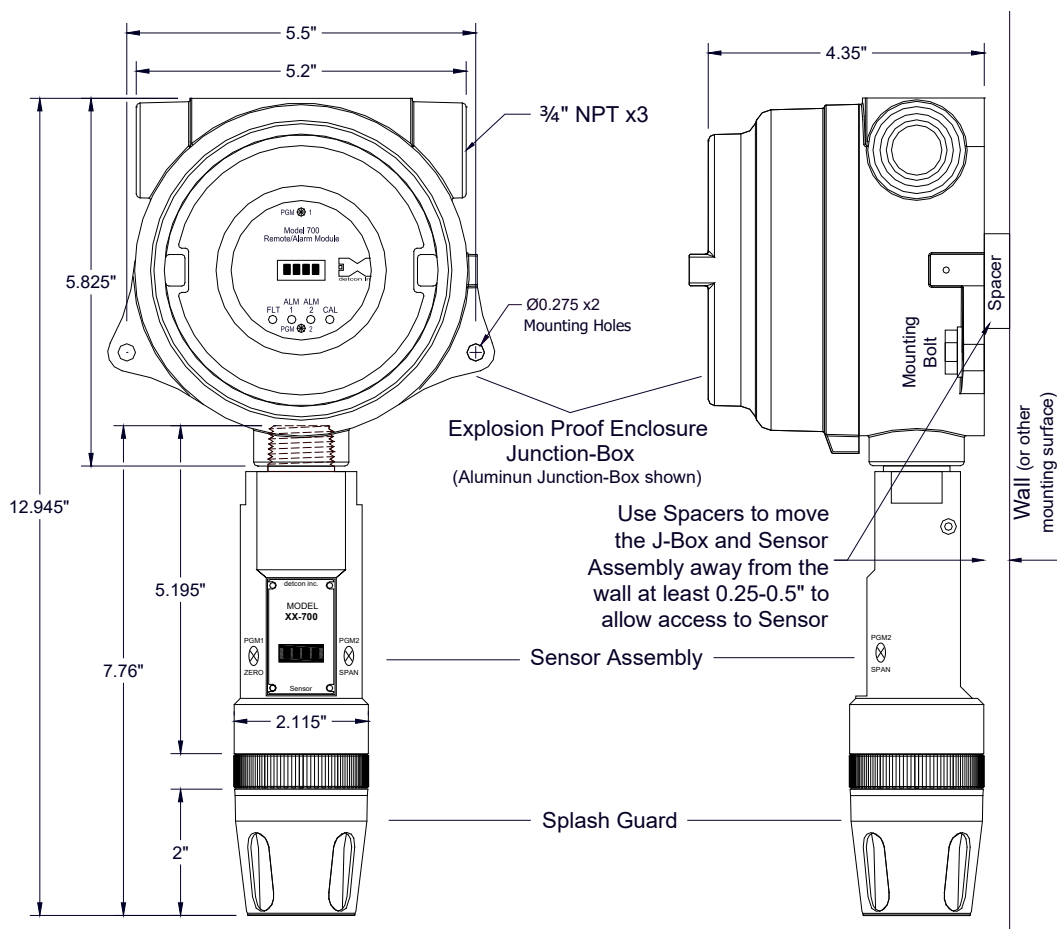

Figure 2 Mounting RAM with 700 Sensor

The RAM Electronics package consists of three printed circuit assemblies (PCAs). The top two PCAs (RAM display and RAM connector board) and the RAM faceplate are enclosed in a molded plastic retaining guard and can be accessed by removing the junction box cover and using the brass pull knobs to pull the package directly out of the enclosure. The bottom PCA (terminal board) will remain attached to the bottom of the junction box via two machine screws allowing the RAM display and RAM connector board to unseat from the 12-pin plug-in connector and provide access to the terminal board connectors (Figure 6). To install the electronics package, properly align the 12-pin plug-in connector and gently push the RAM in until it is fully seated to the terminal board. The RAM faceplate will be even with the top of the junction box when installed.

properly. The RAM top should be flush with the top of the enclosure before screwing down the junction box cover.

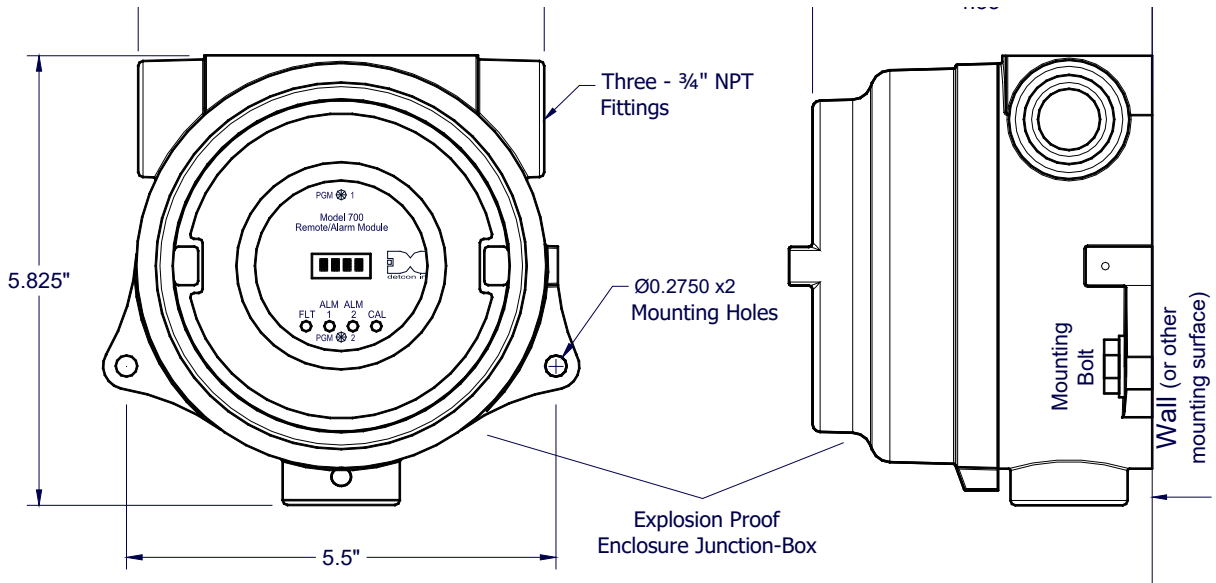

Figure 3 RAM Mounting

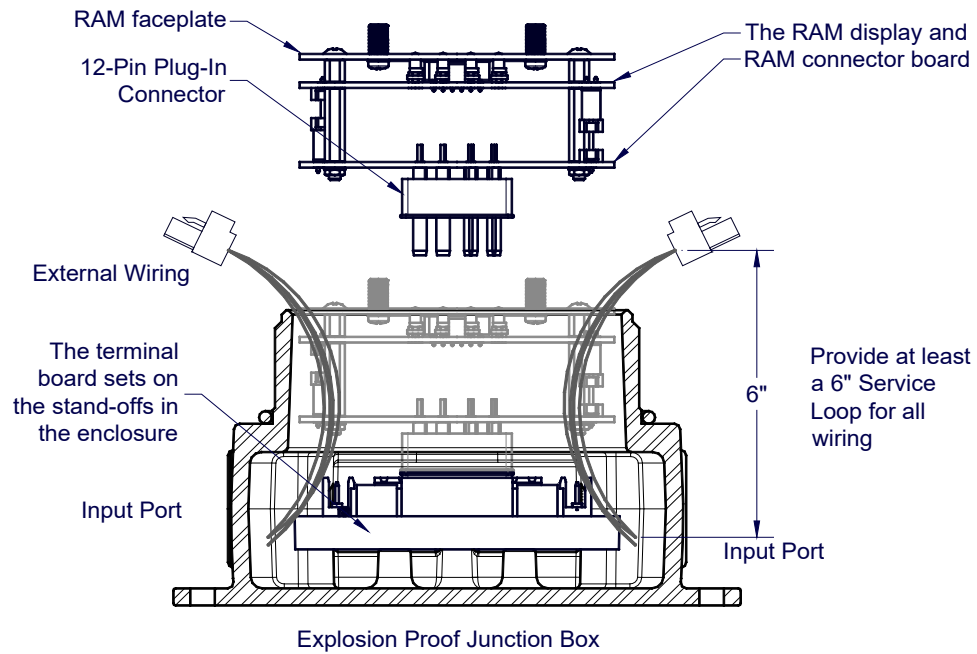

Figure 4 Exploded View of Assembly

NOTE: For products utilizing the aluminum junction box option, the conduit seal shall be placed at the entry to the junction box (see Figure 5 as an example). For products utilizing the stainless steel junction box option, the conduit seal shall be placed within 18” of the enclosure. Crouse Hinds type EYS2, EYD2 or equivalent are suitable for this purpose.

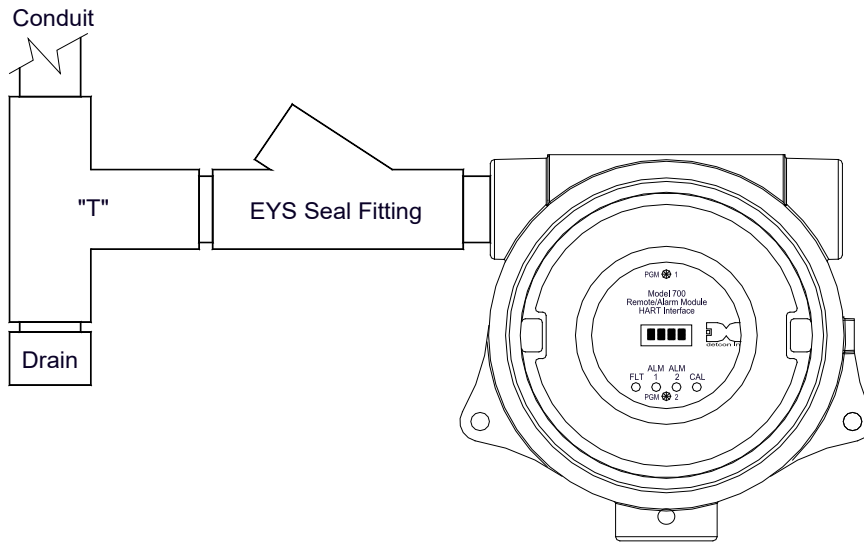

Figure 5 Typical Installation

1.3 Field Wiring

The field wiring connections are made to the bottom PCA (terminal board) of the RAM using a series of connector blocks. There is a 6-pin terminal block for connection to the 700 Gas Sensor (labeled SENSOR), a 9-pin terminal block for connection to the 3 relay contacts (labeled RELAY OUTPUT), a 6-pin terminal block for connection of power, mA output and Modbus™ interface to the host device (labeled IN) and a 6-pin terminal block for connection of power and Modbus™ interface to an additional device (labeled OUT).

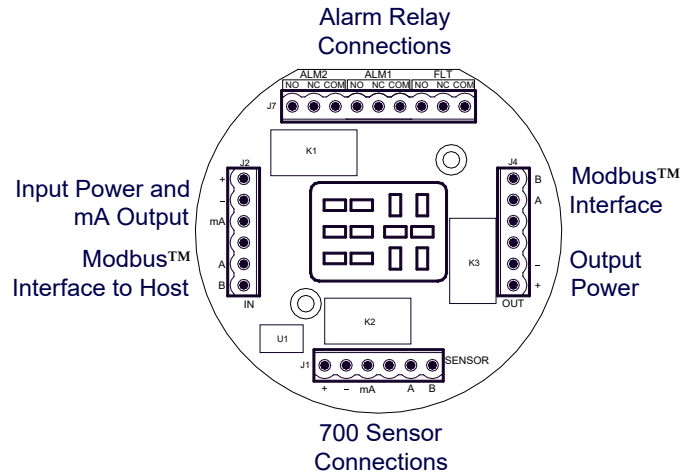

Figure 6 Interface connections on terminal board

The user will typically connect the 700 Gas Sensor directly to the RAM if there is no requirement for remote sensor separation (Figure 7). In this case, the 700 sensor will not require its own junction box and it is not necessary to install/use the Transient Protection Module shipped with the 700 sensor. The 700 sensor may arrive from the factory pre-assembled with the RAM in the j-box, but only if it is ordered in this configuration. In this configuration, the wires from the 700 sensor will be directly connected to the 6-pin terminal block labeled “SENSOR” on the terminal board.

NOTE: If the 700 sensor and RAM are directly connected, it is not necessary to install/use the Transient Protection Module that is shipped with every 700 Gas Sensor.

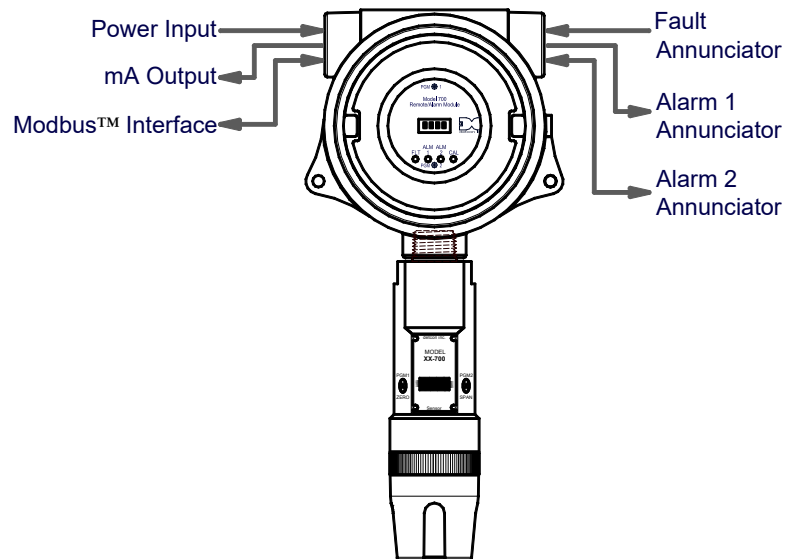

Figure 7 Installation with 700 Gas Sensor

If remote sensor separation is required, the RAM will be separated from the 700 sensor. Remote separation distances of up to 1000 feet are possible with the recommended cables.

NOTE: It is highly recommended to install the interconnecting cabling inside rigid metal conduit to eliminate potential EMI and RFI interference.

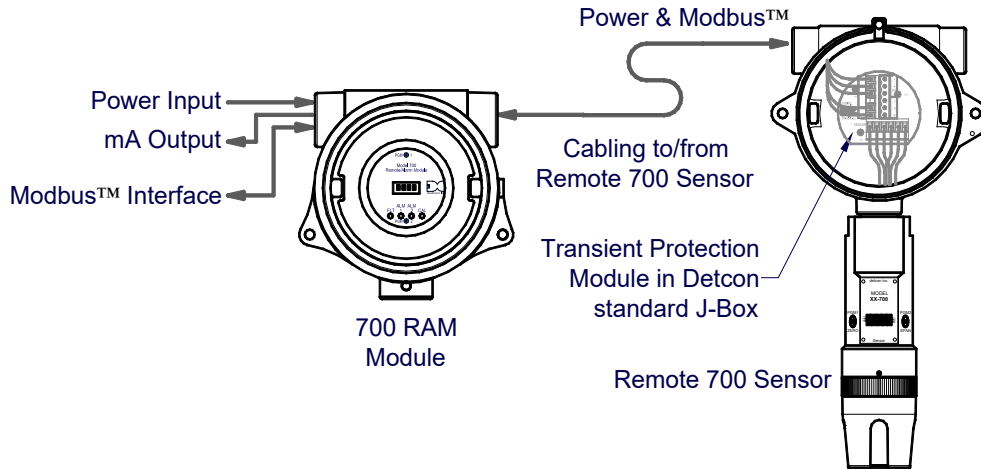

Figure 8 Remote 700 Gas Sensor with RAM

The recommended cable for remote sensor separation is Belden 8770 (18AWG shielded 3-wire cable) for connection of power and mA signal return and Belden 9841 (24AWG shielded twisted pair) for serial Modbus™ communications.

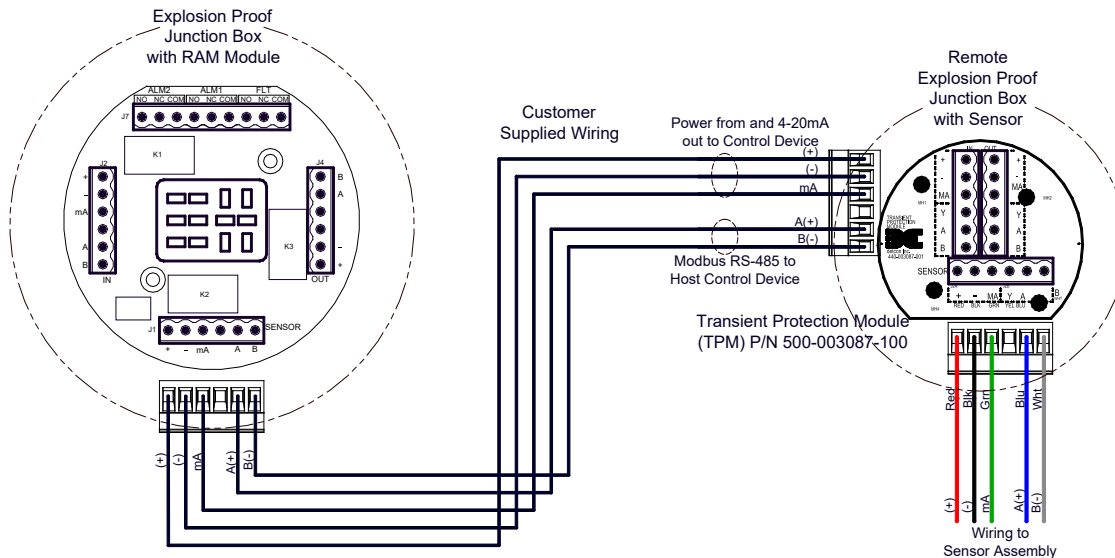

Figure 9 Remote Sensor Wiring

NOTE: Both the 3-wire power/mA cable and the 2-wire Modbus™ serial communications cable are required when remote wiring between the RAM and the 700 Gas Sensor.

NOTE: The same recommended cables should be used for the connection between a Modbus™ master control device and the RAM. However, if only the 4-20mA signal is being used by the master/host controller, then only the 3-wire cable is required.

2. Operator Interface

The operator interface of the RAM is very similar to the Model 700 Gas Sensor. It uses the identical LED display, same programming magnet, and has the same magnetic programming switches (PGM1/ZERO and PGM2/SPAN). The main difference is that the 700 RAM has LED indicators for the 3 relays (ALM1, ALM2 and FAULT) and a CAL LED to indicate when the 700 sensor is in calibration or being polled serially by a master control device.

The gas reading, gas units, and fault status reported by the RAM will mimic that of the 700 Gas Sensor. The Modbus™ output from the RAM repeats the Modbus™ output from the 700 Gas Sensor.

NOTE: If the Model 700 Gas Sensor is directly connected to the RAM and junction box, then the gas sensor operation should be exercised through the 700 Gas Sensor (and not the RAM). This is the recommended practice since the RAM contains a limited number of sensor operational control functions. If the RAM and 700 Gas Sensor are separated, then normal remote gas sensor operation should be exercised through the RAM.

The operating interface is menu-driven via the two magnetic program switches located under the target marks on the RAM faceplate. The two switches are referred to as “PGM1” and “PGM2”. The menu list consists of three major items that include sub-menus as indicated below. (Refer to the complete Software Flow Chart Figure 10)

Normal Operation

Current Reading and Fault Status

Calibration Mode

AutoZero (if applicable)
AutoSpan

Program Mode

View Sensor Status (representative of whichever Model 700 Gas Sensor is attached)
Set AutoSpan Level
Set Serial ID
Alarm 1 Settings
Alarm 2 Settings
Fault Settings
Signal Output Check

The user interface of the RAM is designed to mimic that of the Model 700 Gas Sensor. However, only the functions deemed critical for normal remote sensor operation are available. The 5 menu functions that are available for the remote control of the 700 Gas Sensor are:

AutoZero – used to perform AutoZero remotely

AutoSpan – used to perform AutoSpan remotely, user is required to apply span gas flow to remote gas sensor

View Sensor Status – displays the complete list of sensor status and diagnostic indicators

Set AutoSpan Level – used to change the span gas concentration

Signal Output Check – used to generate simulated outputs from the sensor for system diagnostic purposes

NOTE: For any other required operational changes, the 700 Gas Sensor must be accessed directly.

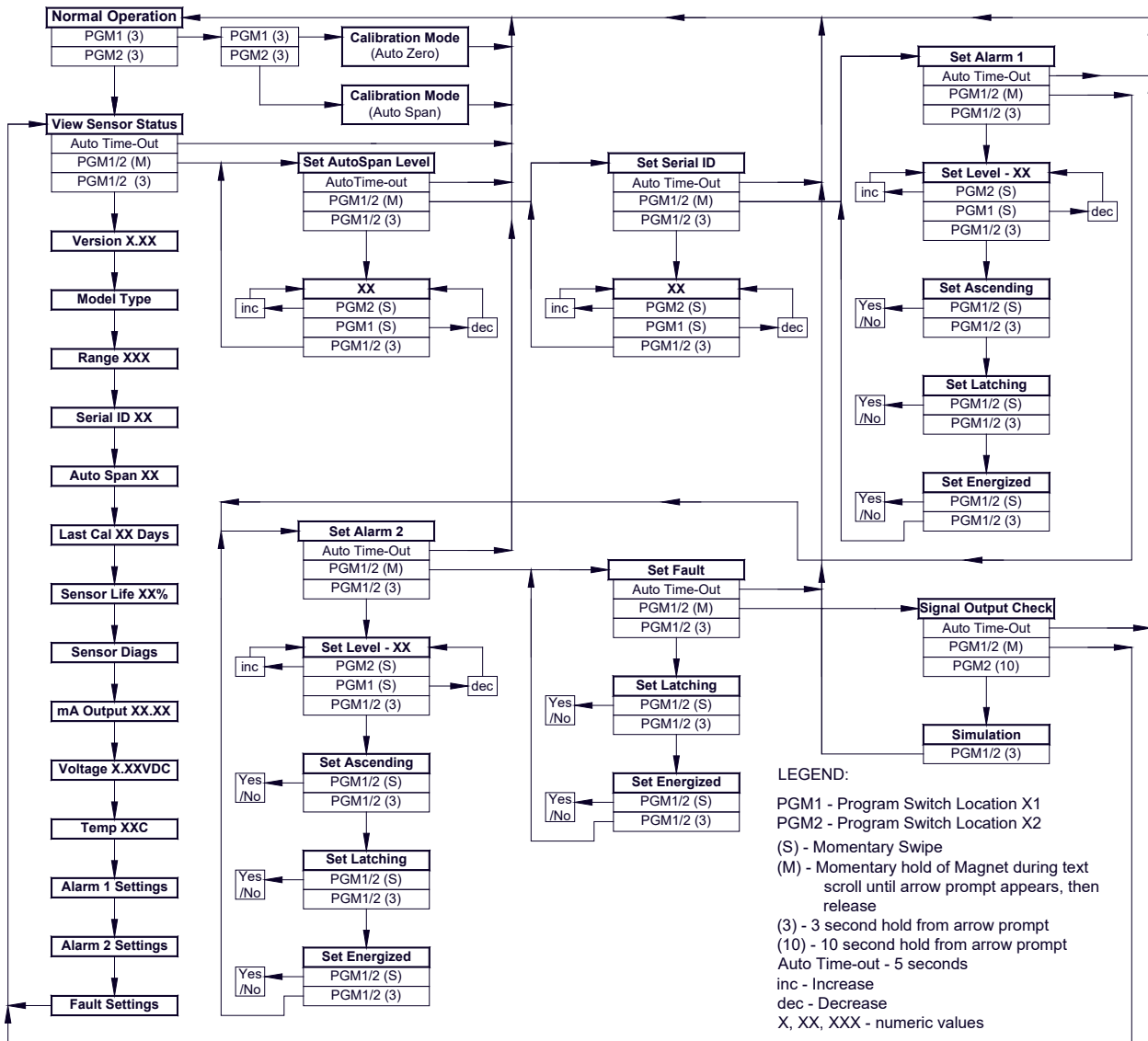

Figure 10 RAM Software Flowchart

3. Set-up and Normal Operation

In normal operation, the RAM display continuously shows the current sensor reading, which will typically appear as “ 0 ”. Once every 1 minute the LED display will flash the sensor’s measurement units and gas type (i.e. % LEL). If the 700 Gas Sensor or RAM is actively experiencing any diagnostic faults, a “Fault Detected” message will flash on the display once every minute. When the unit is in “Fault Detected” mode with the red Fault LED on, PGM1 or PGM2 can be swiped to invoke a display of the active faults.

In normal operation, the 4-20mA current output from the RAM corresponds with the present gas concentration and full-scale range. The RS-485 Modbus™ serial output provides the current gas reading and fault status on a continuous basis when polled.

Successful Modbus™ communications between the RAM and the RS-485 Master Controller will be indicated by a blinking “CAL” LED. If the Modbus™ communication between the RAM and the 700 Gas Sensor is not functioning the RAM will display “COMM” and the “FLT” LED will be illuminated.

NOTE: The 700 Gas Sensor must be set to Serial ID = 01 for proper communications set-up with the RAM.

3.1 View Sensor Status

View Sensor Status displays all current configurational and operational parameters from the 700 Gas Sensor attached to it. These typically include sensor type, software version number, detection range, AutoSpan level, days since last AutoSpan, estimated remaining sensor life, sensor diagnostics, input voltage, 4-20mA output, and sensor ambient temperature.

To access the **View Sensor Status** menu, hold the magnet over PGM2 (⬇) until the arrow prompt appears and then hold continuously for 3 seconds. This will display the **View Sensor Status** text scroll. From the “View Sensor Status” text scroll, hold the magnet over PGM1 (⬆) or PGM2 (⬇) until the arrow prompt appears and then hold continuously for an additional 3 seconds. The display will scroll the complete list of sensor status parameters sequentially:

- Current Software Version (of the RAM)
- Sensor Model Type
- Range of Detection
- Serial ID address
- AutoSpan Level
- Days Since Last AutoSpan
- Remaining Sensor Life
- Sensor Diagnostics (varies by sensor type)
- 4-20mA Output
- Input Voltage Supply
- Sensor Temperature
- Alarm 1 Settings
- Alarm 2 Settings
- Fault Settings

When the sensor status list sequence is complete, the RAM will revert to the “View Sensor Status” text scroll. The user can then choose to either: 1) review list again by executing another 3 second hold, 2) move to another menu item by executing a momentary hold, or 3) return to Normal Operation via 15 second automatic timeout.

3.2 Set AutoSpan Level

Set AutoSpan Level is used to set the span gas concentration level that is being used to calibrate the sensor. This level is adjustable from 10% to 100% of range. The current setting can be viewed in **View Sensor Status**.

The menu item appears as: “Set AutoSpan Level”

From the “Set AutoSpan Level” text scroll, hold the magnet over PGM1 (▲) or PGM2 (▼) until the arrow prompt appears and then hold continuously for an additional 3 seconds. The display will then switch to “XX” (where XX is the current gas level). Swipe the magnet momentarily over PGM2 to increase or PGM1 to decrease the AutoSpan Level until the correct level is displayed. Hold the magnet over PGM1 or PGM2 for 3 seconds to accept the new value. The display will scroll “AutoSpan Level Saved”, and revert to “Set AutoSpan Level” text scroll.

The user can then choose to either: 1) move to another menu item by executing a momentary hold, or 2) return to Normal Operation via 15 second automatic timeout.

3.3 Set Serial ID

The RAM can be polled serially via the RS-485 Modbus™ interface. It repeats the Modbus™ output from the 700 Gas Sensor it is connected to. The RAM Serial ID # should be set as a slave device to a master polling device. The Serial ID # of the RAM is independent of the Serial ID # of the Model 700 Gas Sensor.

NOTE: The Serial ID # of the Model 700 Gas Sensor connected to the RAM must be set to ID = 01 for proper communication between the two devices.

Set Serial ID is used to set the Modbus™ serial ID address of the RAM. It is adjustable from 01 to 127 in hexadecimal format (01-7F hex). The current serial ID can be viewed in **View Sensor Status** using the instruction given in Section 3.1 **View Sensor Status**.

The menu item appears as: “Set Serial ID”

From the “Set Serial ID” text scroll, hold the programming magnet over PGM1 (▲) or PGM2 (▼) until the arrow prompt appears and then hold continuously for an additional 3 seconds. The display will then switch to “XX” (where XX is the current ID address). Swipe the magnet momentarily over PGM2 to increase or PGM1 to decrease the hexadecimal number until the desired ID is displayed. Hold the magnet over PGM1 or PGM2 for 3 seconds to accept the new value. The display will scroll “New ID Saved”, and revert to “Set Serial ID” text scroll.

The user can then choose to either: 1) move to another menu item by executing a momentary hold, or 2) return to Normal Operation via 15 second automatic timeout.

3.4 Set-up for Relay Outputs

The user interface allows for the setting and configuration of the three relay contacts of the RAM. The three relays can be optionally configured as follows:

- Alarm 1: 1) gas level, 2) ascending/descending, 3) latching/non-latching and 4) energized/de-energized
- Alarm 2: 1) gas level, 2) ascending/descending, 3) latching/non-latching and 4) energized/de-energized
- Fault: 1) latching/non-latching and 2) energized/de-energized

The three menu items for relay output set-up are **Alarm1 Settings**, **Alarm2 Settings**, and **Fault Settings**. They are used to set the gas alarm levels and relay status for ascending/descending, latching/non-latching, and energized/de-energized. The gas concentration level for alarms can be set between 1-95% of the full-scale

range of the 700 Gas Sensor. The current relay configurational settings can be viewed in **View Sensor Status** menu.

Ascending/Descending - In ascending mode, the alarm will trigger when the gas concentration detected is greater than or equal to the alarm set point. In descending mode, the alarm will trigger when the gas concentration detected is lesser than or equal to the alarm set point.

Latching/Non-Latching - In latching mode, the relay remains active when the alarm status has cleared. In non-latching mode, the relay is deactivated when the alarm status is cleared.

Energized/De-Energized - In energized mode, the normally open contact is closed if the alarm level has not been reached. In non-energized mode, the normally open contact is open if the alarm level has not been reached. Energized mode provides for fail-safe operation since a loss of power or cable failure will cause the contact to be open.

The menu item appears as: “Alarm1 Settings”

From the “Alarm1 Settings” text scroll, hold the magnet over PGM1 (▲) or PGM2 (▼) until the arrow prompt appears and then hold continuously for an additional 3 seconds. The display will switch to “Set Level” followed by “XX” (where XX is the current set-point level). Swipe the magnet momentarily over PGM2 to increase or PGM1 to decrease until the correct level is displayed. Hold the magnet over PGM1 or PGM2 for 3 seconds to accept the new value. The display will scroll “Saved”.

The display will then scroll “Set Ascending” and show “Yes” or “No”. Use a swipe of PGM1 to select choice (yes = ascending and no = descending). Use PGM1 for a 3 second hold to accept the selection. The display will scroll “Saved”.

The display will then scroll “Set Latching” and then show “Yes” or “No”. Use a swipe of PGM1 to select choice (yes = latching and no = non-latching). Use PGM1 for a 3 second hold to accept the selection. The display will scroll “Saved”.

The display will then scroll “Set Energized” and then show “Yes” or “No”. Use a swipe of PGM1 to select choice (yes = energized and no = non-energized). Then use PGM1 for a 3 second hold to accept the selection. The display will scroll “Saved”.

At this point, configuration settings for Alarm1 are complete and the menu will shift back to “Alarm1 Settings”. The user can then choose to either: 1) move to another menu item by executing a momentary hold at the end of the text scroll, or 2) return to Normal Operation via 15 second automatic timeout.

Follow the identical instructional sequence for the menu function “Alarm2 Settings”. The menu function for “Fault Settings” is similar except that it does not have a selection for gas level and ascending/descending. It only has choice selections for latching/non-latching and energized/de-energized.

NOTE: The Fault relay is typically set-up as energized so that it will change states during an unexpected power loss.

NOTE: The relay contacts can be wired at the RAM’s connector PCA for either Normally Open or Normally Closed.

3.5 Signal Output Check

Signal Output Check provides a simulated 4-20mA output and RS-485 Modbus™ output. The simulation allows the user to conveniently perform a functional system check of the entire safety system, and can be initiated at the RAM. This signal output simulation aids in performing troubleshooting of signal wiring problems.

This menu item appears as: “Signal Output Check”.

From the “Signal Output Check” text scroll, hold the magnet over PGM1 (⬆) or PGM2 (⬇) until the arrow prompt appears and then hold continuously for an additional 3 seconds. Once initiated, the display will continuously scroll “Simulation Active” until the function is stopped. During simulation mode, the 4-20mA value will be increased from 4.0mA to 20.0mA (in 1% of range increments at a 1 second update rate) and then decreased from 20.0mA to 4.0mA. The same simulation sequence is applied to the Modbus™ output gas reading.

NOTE: Signal Output Check stays active indefinitely until the user stops the function. There is no automatic timeout for this feature.

To end simulation mode, hold magnet over PGM1 (⬆) or PGM2 (⬇) until the arrow prompt appears and then hold continuously for an additional 3 seconds. The display will revert to either the prior menu item or the next menu item respectively.

The user can then choose to either: 1) move to another menu item by executing a momentary hold, or 2) return to Normal Operation via 15 second automatic timeout.

4. RS-485 Modbus™ Protocol

The RAM module provides a Modbus™ compatible communications protocol and is addressable via the program mode. This Modbus™ output is exactly repeated from the specific Model 700 sensor that is attached. Communication is two-wire, half duplex RS-485, 9600 baud, 8 data bits, 1 stop bit, no parity, with the sensor set up as a slave device. An RS-485 Master Controller up to 4000 feet away can theoretically poll up to 256 different RAM's. This number may not be realistic in harsh environments where noise and/or wiring conditions would make it impractical to place so many devices on the same pair of wires. If a multi-point system is being utilized, each RAM must be set for a different address. Typical address settings are: 01, 02, 03, 04, 05, 06, 07, 08, 09, 0A, 0B, 0C, 0D, 0E, 0F, 10, 11...etc.

Successful Modbus™ communications between the RAM and an RS-485 Master Controller is indicated by a blinking “CAL” LED. If the Modbus™ communication between the RAM and the 700 Gas Sensor is not functioning, the RAM will display “COMM” and the “FLT” LED will be illuminated.

NOTE: The 700 Gas Sensor must be set to Serial ID = 01 for proper communications set-up with the RAM.

RS-485 ID numbers are factory default to 01. These can be changed in the field via the Operator Interface described in Section 3.3, Set Serial ID.

NOTE: Refer to the Model 700 Gas Sensor Instruction Manual for details on the Modbus™ protocol registers.

5. RAM Electronics Warranty

Teledyne Detcon Inc. warrants, under intended normal use, each new Model 700 RAM module to be free from defects in material and workmanship for a period of two years from the date of shipment to the original purchaser. All warranties and service policies are FOB the Detcon facility located in The Woodlands, Texas.

Terms & Conditions:

- Shipping point is FOB the Teledyne Detcon factory.
- Net payment is due within 30 days of invoice.
- Detcon, Inc. reserves the right to refund the original purchase price in lieu of RAM replacement.

6. Specifications

Inputs

Any Model 700 Gas Sensor

See specific Model 700 Gas Sensor manual for specifications of the sensor

Outputs

4-20mA signal

Relay Contacts - Three Form C contacts rated for 5A @ 30 VDC/250 VAC

RS-485 Modbus™ RTU

Input Voltage

11.5 - 30VDC

Power Consumption (excluding 700 Gas Sensor)

< 0.5 Watts at 24VDC (Normal)

< 1.0 Watts at 30VDC (Maximum)

Operating Temperature

-40°C to +70°C

Electrical Classification

Class 1, Division 1 Groups BCD

Class 1, Zone 1 AEx d IIB+H2

Ex db IIB+H2 T4 Gb

EN 60079-0:2018

EN 60079-1:2014

EN 50270:2015

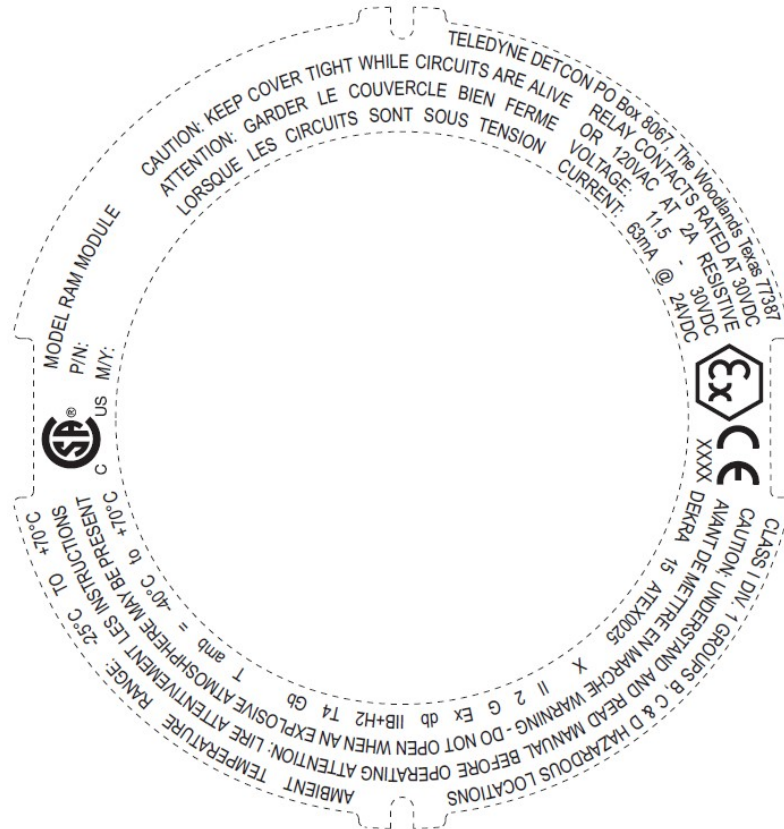

Figure 11 RAM Label

7. Spare Parts

Part Number	Spare Parts
500-005136-100	RAM Display PCA
500-005135-100	RAM Connector Board
500-005134-100	Termination Board PCA
897-850901-010	Aluminum Condulet w/Glass Lens Cover
897-850901-316	SS Condulet w/Glass Lens Cover
8522-750	3/4" NPT Plug
960-202200-000	Condensation Prevention Packet
306-175705-100	6-Pin Connector
306-175708-000	9-Pin Connector

8. Revision Log

Revision	Date	Changes made	Approval
1.0	03/16/2011	Made changes to reflect new RAM assembly.	LU
1.1	11/06/14	Update Remote Wiring Diagram	LU
2.0	11/07/15	Update for ATEX requirements	MJM
2.1	06/07/18	Updated Section 1.2 Conduit Seal	MM
2.2	12/09/19	Updated Company Information and Label	MM