

UNIVERSAL DISPLAY MODULE

MODEL UDM-001 / UDM-002



UDM-001

Operator's Installation and Instruction Manual

Distributed By
Protek Safety & Controls Ltd.
#10, 1715 – 27th Ave NE
Calgary, AB T2E 7E1
Ph.403-668-6869 / Fax 403-668-6865
www.proteksc.com

This page left intentionally blank

Table of Contents

1. Introduction.....	1
1.1 Features	1
1.2 Compatible Gas Detectors	1
2. Safety Guidelines for Safe Use	1
3. Installation.....	2
3.1 Mounting	2
3.2 Field Wiring	2
4. Startup / Configuration	4
4.1 Startup	4
4.2 Operator Interface.....	4
4.3 Magnetic Programming Tool.....	4
5. Operational Menus	5
5.1 Normal Operation	5
5.2 Operation During a Fault Condition	5
5.3 View Sensor Status Menu	6
5.4 Set Autospan Level Menu	7
5.5 Zero Calibration	7
5.6 Span Calibration	7
5.7 Turning the Display OFF and ON	8
5.8 Programming Flowcharts	10
6. Maintenance and Service Personnel Activities.....	13
7. Troubleshooting Guide.....	13
7.1 General Troubleshooting	13
7.2 Detcon Sensor Specific Troubleshooting	13
7.3 Sensor Electronics Corp Sensor Specific Troubleshooting	14
8. Customer Support and Service Policy	14
9. Warranty Notice	15
10. Specifications.....	15
10.1 Revision Log	16

List of Figures

Figure 1: Mounting details.....	2
Figure 2: UDM Wiring Diagram	3
Figure 3: Programming Magnet.....	4
Figure 4: Detcon 700 Series Programming Flowchart	11
Figure 5: SEC 3000 Series Programming Flowchart.....	11
Figure 6: SEC Millenium Series Programming Flowchart.....	12

1. Introduction

1.1 Features

The Universal Display Module is a single or dual channel remote display module designed to achieve remote sensor separation for up to two gas detectors. It is designed to be universal across multiple brands of gas detection allowing the user to interact with the same interface but utilize the best technology for the application within those compatible brands. The UDM is provided in an epoxy painted explosion-proof enclosure with a viewing window.

The UDM display allows the 4-20mA output signal to pass directly through from the attached gas detector on each channel and does not interrupt or re-create the 4-20mA signal. The UDM acts as a digital communication master to each attached gas detector and displays the concentration, plus is as an interface to access the gas detectors menu structure for calibration and various parameter configurations. Additional parameters may be found by accessing each detector directly depending on the make and model of the gas detector connected.

1.2 Compatible Gas Detectors

Below is a list of compatible gas detectors at the time of this manual release.

- Detcon 700 series including FP700, DM700 (except DM-700-O2), IR700, TP700
- Sensor Electronics Millennium Series
- Sensor Electronics SEC3000 Series

2. Safety Guidelines for Safe Use

If equipment is used in a manner not specified in the manual, the protection provided by the equipment may be impaired. It is mandatory to read and follow all the Safety Warnings and Cautions listed below and throughout the manual.



Warning

- When installed in a Class 1, Div 1 / Class 1, Zone 1 area, seals are required as per the certification label.
- When installed in a Class 1, Div 2 / Class 1, Zone 2 area, seals are **NOT** required as per the certification label.



Warning

- Explosion Hazard. Do not open the enclosure or make any disconnections while the circuit is live or unless the area is known to be free of ignitable concentrations.
-

3. Installation

3.1 Mounting

The UDM can be installed as a wall mount using the mounting tabs of the explosion-proof junction box. Once mounting of the housing is complete, the UDM PCBA can be oriented on the square pattern stand-off's to ensure the OLED display is horizontal for viewing.

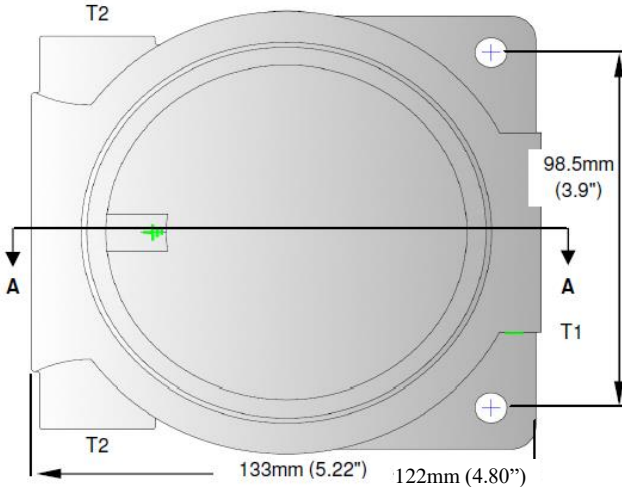

Figure 1: Mounting details

The UDM electronics package consists of one printed circuit assembly (PCA) and a top graphics plate with two captive thumb screws to allow for removal of the PCA assembly from the housing. To install the electronics package, ensure power is off, properly align the 4 holes in the PCA with the four stand-off's in the housing, slide the electronics assembly down the standoff's until the faceplate rests on the stand-off's. Next, tighten the two captive screws onto the stand-off's, (hand tight only) and install the enclosure cover.

3.2 Field Wiring

The field wiring connections are made to the bottom of the UDM PCA using removable terminal blocks. There are three 6-pin terminal block on the bottom of the PCA, Sensor #1, Sensor #2 (if applicable), and Power / Output connections as shown in Figure 2.

If remote sensor separation is required, the UDM can be separated from the gas detector. Remote separation distances of up to 1000 feet are possible with the recommended cables.

The recommended cable for remote sensor separation is Belden 8770 (18AWG shielded 3-wire cable) for connection of power and mA signal return and Belden 9841 (24AWG shielded twisted pair) for serial Modbus™ or digital communications.

NOTE: It is highly recommended to install the interconnecting cabling inside rigid metal conduit to eliminate potential EMI and RFI interference.

UNIVERSAL DISPLAY MODULE - SENSOR SEPARATION WIRING DIAGRAM

** Two Channel UDM (UDM-002) shown for illustration purposes **

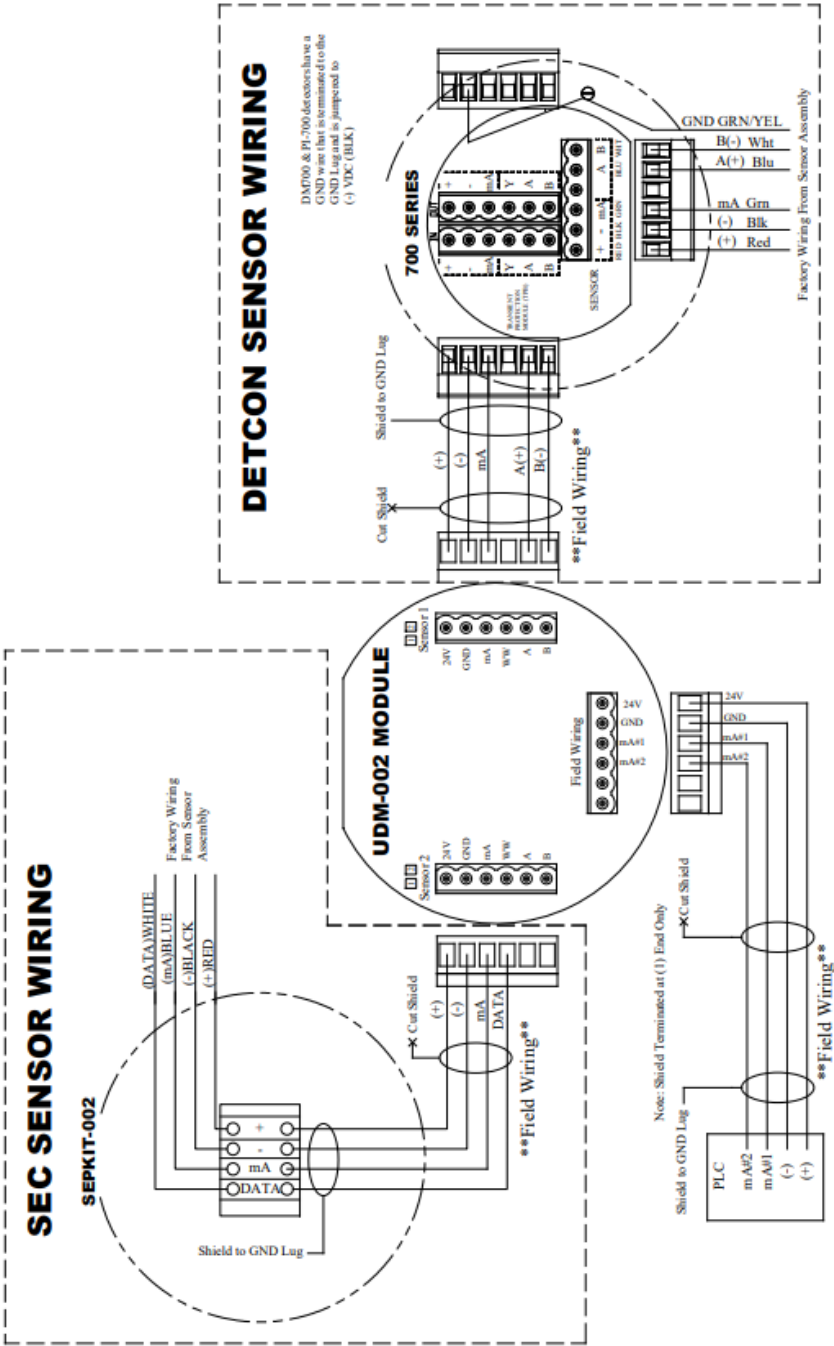

Figure 2: UDM Wiring Diagram

4. Startup / Configuration

4.1 Startup

On power-up of the UDM, it will search for connected detectors. If it finds a detector connected it will upload the detector and parameters to the UDM and display the model connected along with the concentration and gas type (i.e. LEL, H2S, SO2). If no sensor is found during the search, the UDM will stop searching and display COMM FAULT on the display for that channel.

Important Notes

- To initiate a new search, a power recycle must be performed.
- Detcon 700 Series Gas Sensor's must be set to Serial ID = 01 for proper communications with the UDM.
- The UDM does not interrupt or re-create the 4-20mA signal from the attached detector. Therefore, if there is a UDM failure, the attached detector will still send the 4-20mA signal back to the higher-level system and be operational. **i.e. The 4-20mA signal output will not be affected and will be operating properly at the PLC but you will lose the ability to remotely access the detector via the UDM's magnetic interface.**
- If one channel on a dual channel UDM is in COMM FAULT, it has no effect on the other channel.

4.2 Operator Interface

The operator interface of the UDM is very similar to the Detcon Model 700 series detectors. It uses two magnetic programming switches per channel (PGM1/ZERO and PGM2/SPAN) and utilizes the same programming magnet. When activating the magnetic switches on the UDM, you are interfacing to the attached detector via various serial communication protocols depending on the make and model of the detector. The UDM interface is designed to mimic the Model 700 series Detcon detector interface even when other brands are connected to give the user consistency when operating the menu structure. However, only the functions deemed critical for normal remote sensor operation are available via the UDM. Other menu functions may be available via the detector itself depending on the make and model connected to the UDM.

4.3 Magnetic Programming Tool

The magnetic programming tool is used to operate the magnetic switches. To activate the magnetic switch, move the magnet over the circle near each PGM marking on the faceplate. You will see the arrow on the display indicating that the switch is activated.



Figure 3: Programming Magnet

5. Operational Menus

The menu structures are as follows:

Normal Operation

Current Reading and Fault Status

Calibration Mode

AutoZero

Autospan

Program Mode

View Sensor Status

Set Autospan Level (If applicable)

Display ON/OFF

5.1 Normal Operation

In normal operation, the UDM display continuously shows the current sensor concentration and measurement unit for each channel (i.e. 0% LEL, or 0ppm H₂S). With gas concentrations below 10% of the sensors range the status LED will be green for its respective channel.

At 10% of the detectors range the status LED will flash red to indicate that gas is present.

In normal operation, each 4-20mA current output displays the gas concentration and full-scale range of the corresponding channel.

5.2 Operation During a Fault Condition

If a channel is actively experiencing any diagnostic faults, a fault message will be present on the display until the channel fault is resolved. When a fault is detected, the status LED will turn amber and flash.

During a fault condition, the 4-20mA current output signal will be a low mA reading (dependant on the Make and Model of detector attached). See the appropriate detector manual for more details.

5.3 View Sensor Status Menu

The “**View Sensor Status**” menu displays some of the parameters from the connected detectors and will vary depending on the Make and Model of the detector attached.

To access the “**View Sensor Status**” menu:

- 1) Hold the magnet over PGM2, of the channel you want to access.
- 2) When the arrow prompt appears hold the magnet continuously for 3 seconds, “**View Sensor Status**” text will scroll.
- 3) When the “**View Sensor Status**” text scrolls, hold the magnet over PGM2.
- 4) When the arrow prompt appears, hold continuously again for 3 seconds. This will bring you into the “**View Sensor Status**” menu and the display will start to scroll the complete list of sensor status parameters sequentially. You can now remove the magnet.
- 5) When the sensor status list sequence is complete, the display will revert to the “**View Sensor Status**” text scroll and after a few seconds revert to normal operation.

Detcon Model 700 Series Sensors Display:

- Sensor Range
- Autospan Level
- Sensor Life
- Model Type
- Days Since Last Cal
- 4-20mA Output
- Input Voltage
- Sensor Temperature

Note: Sensor Diagnostics (varies by sensor type)

Sensor Electronics Millenium Series Detectors Display:

- Sensor Range
- Autospan Level
- Gas Curve
- Model Type
- Sensor Temperature

Sensor Electronics 3000 Series Detectors Display:

- Sensor Range
- Autospan Level
- Model Type
- Sensor Temperature

5.4 Set Autospan Level Menu

“Set Autospan Level” is used to set the span gas concentration level that is being used to calibrate the sensor. This adjustable level is dependant on the detector attached. Refer to the applicable detector manual. The current setting can be viewed in “View Sensor Status”, but you can also enter the “Set Autospan Level” menu to make changes.

To access the “Auto Span Level” menu:

- 1) Hold the magnet over PGM2, of the channel you want to access.
- 2) When the arrow prompt appears hold the magnet continuously for 3 seconds, “View Sensor Status” text will scroll.
- 3) When the “View Sensor Status” text scrolls, hold the magnet over PGM2.
- 4) As soon as the arrow prompt appears, remove the magnet away.
- 5) When the “Auto Span Level” text scrolls, hold the magnet over PGM2.
- 6) When the arrow prompt appears, hold continuously again for 3 seconds. This will bring you into the “Auto Span Level” menu and display the current span gas level setting.
- 7) Swipe the magnet momentarily over PGM 1 to increase or PGM 2 to decrease the value until the correct span level is displayed.
- 8) Hold the magnet over PGM 2 for 3 seconds to accept the new value.
- 9) The display will show “Autospan Level Saved”.
- 10) The display will revert to the “Auto Span Level” text scroll and after a few seconds revert to normal operation.

5.5 Zero Calibration

A zero calibration can be performed on all sensors by accessing the UDM calibration menu. Intervals for zero calibration are dependent on the attached make and model of detector. Details regarding the zero calibration frequency can be found in the applicable detector manual.

To access the **Zero Calibration** menu:

- 1) Hold the magnet over PGM1, of the channel you want to access.
- 2) When the arrow prompt appears hold the magnet continuously for 3 seconds, “PGM1 = Zero ... PGM2 = SPAN” text will scroll.
- 3) Hold the magnet on PGM1 and when the arrow appears, continue to hold for 3 seconds until the zero calibration is started and “Setting Zero” scrolls on the display.
- 4) Once the zero calibration is finished, the display will say “Zero Cal Complete”
- 5) The detector will return to normal operation.

Note: During zero calibration, the detector output will either go to 2mA or stay at 4mA depending on the detector attached.

5.6 Span Calibration

A zero calibration can be performed on all sensors by accessing the UDM calibration menu. Intervals for span calibration are dependent on the attached make and model of detector. Details regarding the span calibration frequency can be found in the applicable detector manual.

To access the “**Span Calibration**” menu:

- 1) Hold the magnet over PGM1, of the channel you want to access.
- 2) When the arrow prompt appears hold the magnet continuously for 3 seconds, “**PGM1 = Zero ... PGM2 = SPAN**” text will scroll.
- 3) Hold the magnet on PGM2 and when the arrow appears, continue to hold for 3 seconds until span calibration is started and “**Setting Span**” scrolls on the display.
- 4) When “**Apply Gas**” scrolls on the display, apply to required span gas to the detector and wait for the UDM to advise if the calibration is accepted.
- 5) If a calibration is successful, the display will “**Remove Gas**”.
- 6) Once gas is removed and the gas level returns close to “0” on the display, the display will say “**Span Complete**”
- 7) The detector will return to normal operation.

Note: During the span calibration, the detector output will go to 2mA until calibration is finished.

5.7 Turning the Display OFF and ON

The UDM display can be switched into OFF, individually for each channel. This feature can be useful when using a dual channel UDM with a single detector. The procedure will vary depending on if the UDM is connected to a detector or not.

To turn the UDM display OFF:

- 1) Hold the Magnetic Programming Tool to PGM2 of the selected channel for three seconds.
- 2) “**View Sensor Status**” will scroll across the screen. When you see the arrow, pull the magnet away from PGM2.
For Detcon or SEC 3000 detectors continue to step #3
For SEC Millennium detectors proceed to step #4
- 3) “**Set AutoSpan Level**” will scroll across the screen. When you see the arrow, pull the magnet away from PGM2.
- 4) “**Display ON/OFF**” will scroll across the screen. Hold the magnet on PGM#2 until you enter into this menu.
- 5) “**Display ON**” will be on the display. Toggle the “**Display ON**” to “**Display OFF**” by placing and removing the magnet on PGM2.
- 6) Once you have the display reading “**Display OFF**”, Hold the magnet on PGM2 to save. Remove the magnet and wait for the display to return to the normal operation where “**Display OFF**” will be displayed.

In COMM fault the display can be turned to OFF mode by following these steps:

1. Hold the Magnetic Programming Tool to PGM2 of the selected channel for three seconds “**Display ON/OFF**” should scroll across the screen.
2. Hold the Magnetic Programming Tool to either PGM1 or PGM2 for three seconds.
3. “**Display ON**” will be on the display. Toggle the “**Display ON**” to “**Display OFF**” by placing and removing the magnet on PGM2.

4. Once you have the display reading “**Display OFF**”, Hold the magnet on PGM2 to save. Remove the magnet and wait for the display to return to the normal operation where “**Display OFF**” will be displayed.

Turning the display ON from OFF mode by following these steps:

1. Hold the Magnetic Programming Tool to PGM2 of the selected channel for three seconds “**Display ON/OFF**” should scroll across the screen.
2. Toggle the “**Display OFF**” to “**Display ON**” by placing and removing the magnet on PGM2.
3. Once you have the display reading “**Display ON**”, Hold the magnet on PGM2 to save. Remove the magnet and wait for the display to return to the normal operation. The UDM will reboot, search and connect to the existing detector(s).



Warning

- Turning the display to “OFF” **DOES NOT** interrupt or alter the 4-20 mA signal or the operational characteristics of any connected detector.
-

5.8 Programming Flowcharts

The following flowcharts depict the menu structures to program all compatible detectors for the UDM.

Detcon 700 Series Programming Flowchart

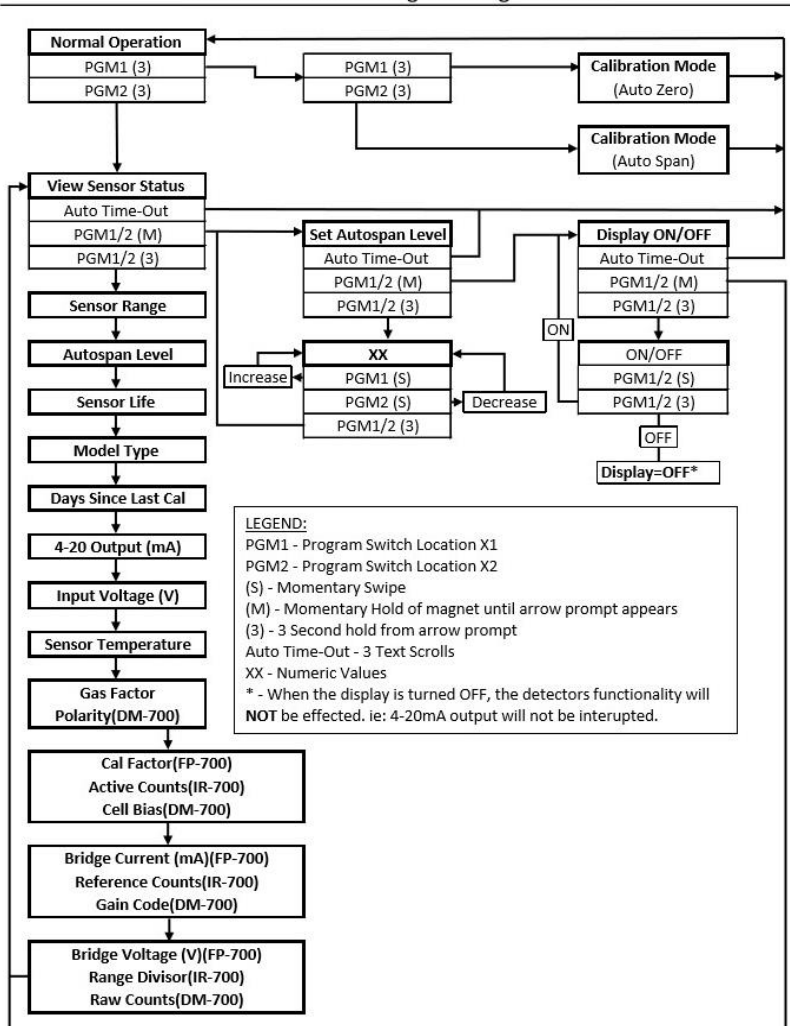
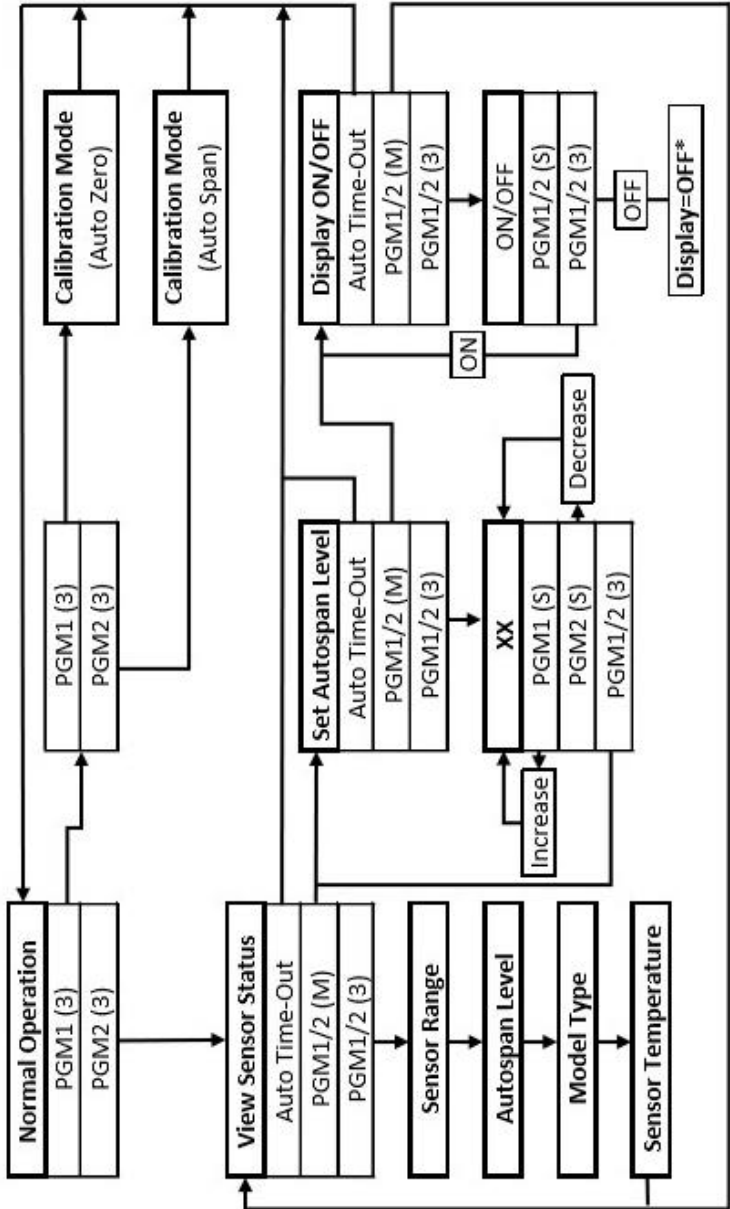

Figure 4: Detcon 700 Series Programming Flowchart

SEC 3000 Programming Flowchart



SEC Millennium Programming Flowchart

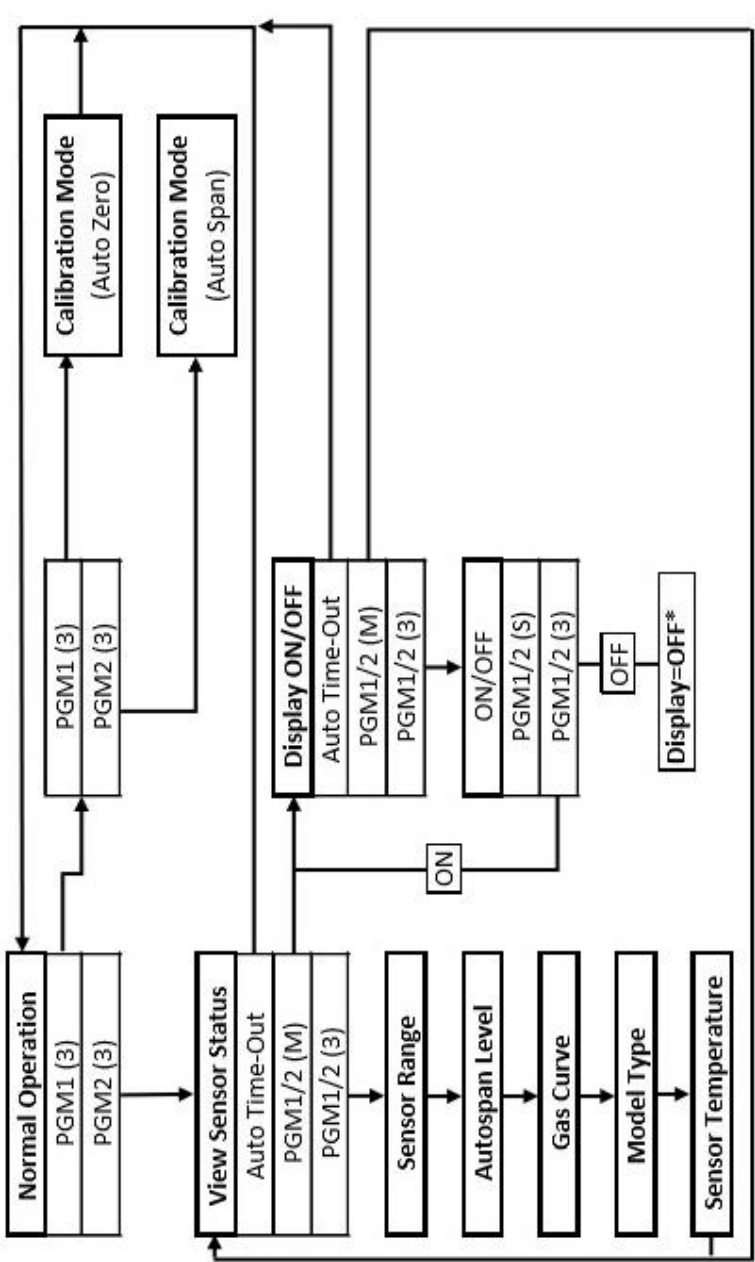

Figure 6: SEC Millennium Series Programming Flowchart

6. Maintenance and Service Personnel Activities

NOTE

Service and maintenance activities should be completed according to individual manufacturer specification and should be performed by trained individuals. Any other required service or maintenance related activity shall only be performed by a Factory-Certified technician.

7. Troubleshooting Guide

7.1 General Troubleshooting

Communication Fault (COMM Fault):

- Is the channel being used? If no detector is connected to that channel, turn off the display for that channel only to avoid getting the COMM FAULT message. See Section 5.7.

Note: If one channel on a dual channel UDM is in COMM FAULT, it has no effect on the other channel.

- Check that the terminal block is correctly seated and the wiring to the UDM module is correct for the compatible detector.
- For Detcon Model 700 Series Gas Sensors, ensure that the Serial ID is set to address “01” for proper communications with the UDM. The address for the Model 700 is set by accessing the Model 700 menu.
- Check wiring connections if all connections are good **recycle power** to restart detector searching.

7.2 Detcon Sensor Specific Troubleshooting

0.00mA Output / -11 on the display:

This indicates that the Detcon gas detector is in a fault condition. The specific fault condition will scroll across the UDM or can be viewed on the Detcon (ITM) by touching the magnet momentarily on PGM-1 or PGM-2. Refer to the Detcon specific manual for the specific fault condition and resolution.

“WAIT” continuously scrolling on the display:

The 4-20mA output is not connected. Check the 4-20mA loop. If the wiring is connected properly, break the loop in the following places and measure the 4-20mA output from that point to common of the power supply:

- inside the Detcon separation kit from the green wire (4-20mA) to the black wire (common). If the 4-20mA is measuring correctly, reconnect the loop and proceed. If not, call support for further steps.
- on the field wiring side of the separation kit terminal block (TPB) break the loop and measure from the output 4-20mA terminal to the common terminal. If the 4-20mA is measuring correctly, reconnect the loop and proceed. If not, the TPB is most likely blown.

Refer to the Detcon model specific manual for the other fault condition and resolution.

7.3 Sensor Electronics Corp Sensor Specific Troubleshooting

SEC Error Codes:

Code	Fault Description	Resolution
3, 11, 12	Zero Calibration Faults	Complete a new zero calibration using zero gas
4, 15, 16	Span Calibration Faults	Complete a new span calibration - ensure span gas concentration is correct for the sensor range. - use a 1.0LPM minimum regulator - if the sensor location has moving air flow, you may need to stop the air flow from carrying away the span gas: <u>Millenium IR Detector</u> - you may need a calibration sleeve or make shift wind block to stop wind from entering the side holes on the housing baffle. <u>SEC3000 Series</u> - you may need a calibration adapter only vs the calibration / splash guard adapter or a make shift wind block to stop wind from entering the side slots on the existing calibration / splash guard adapter.
8	Zero Drift Fault	Complete a new zero calibration using zero gas. Also, Check response and perform a span calibration if required.
9, 10, 25, 26	Input Voltage Issue	Confirm the voltage is between 18-30 Vdc at the sensor input terminals.
13, 14	Dirty Optics Faults	Millenium series specific fault - Clean the internal optics. See Section V of the Millenium manual for details.
21, 24	Span Calibration Faults	SEC3000 series specific fault - Perform a zero and span calibration.

8. Customer Support and Service Policy

Protek Safety & Controls Ltd.
 #10, 1710 – 27th Ave NE
 Calgary, AB T2E7E1

All Technical Service and Repair requests should be sent to Protek’s Service Department by calling 403-668-6869 or emailing service@proteksc.com. RMA numbers should be obtained from the Protek Service Department prior to equipment being returned. For on-line technical service, have the model number, part number, and serial number of product(s) in question available.

All Sales requests (including spare parts purchase) should be sent to Protek’s Safety & Controls Ltd. by calling 403-668-6869 or emailing sales@proteksc.com.

9. Warranty Notice

Protek Safety & Controls Ltd. warrants, under intended normal use, each new UDM module to be free from defects in material and workmanship for a period of two years from the date of shipment to the original purchaser. All warranties and service policies are FOB Protek Safety & Controls Ltd., Calgary Alberta.

Terms & Conditions:

- Shipping point is FOB Protek Calgary.
- Net payment is due within 30 days of invoice.
- Protek Safety & Controls Ltd. reserves the right to refund the original purchase price in lieu of UDM replacement.

Except for the express warranty stated above, Protek Safety & Controls Ltd. disclaims all warranties regarding the products sold. Including all implied warranties of merchantability and fitness and the express warranties stated herein are in lieu of all obligations or liabilities on the part of Protek Safety & Controls Ltd. for damages including, but not limited to, consequential damages arising out of, or in connection with, the performance of the product.

10. Specifications

Inputs

Detcon Model 700 Gas Detectors (except DM-700-O2)
Sensor Electronics Millenium Detectors
Sensor Electronics 3000 Series Detectors (except SEC3000-O2)
***Detector Models to be verified for functionality at time of quote

Outputs

4-20mA (3 wire device configuration) from each available channel

Input Voltage

10.5-30VDC (determined by voltage of attached detector(s))

Power Consumption (excluding attached Gas Sensors)

< 0.5 Watts at 24VDC (Normal)

Operating Temperature

-40°C to +75°C

Electrical Classification

Class I Division 1 Group B, C, D T4 (Seals Required)
Ex db IIB T4 Gb (Seals Required)
Class I Zone 1 AEx db IIB T4 Gb (Seals Required)
Class I Division 2 Group A, B, C, D T4 (No Seals Required)
Class 1 Zone 2, Group IIC T4 (No Seals Required)
-40°C ≤ Tamb ≤ 85°C

Conforms to CSA C22.2 No.152 M(1984) R2016

Enclosure Classification

NEMA4X, IP66/67

10.1 Revision Log

Revision	Date	Changes made	Approval
0	11/25/21	Released	TM
1	12/14/21	Add content, edits	TM
2	06/15/22	Updated wiring Diagrams for Detcon product	TM
3	01/24/23	Updated certification details	TM
4	02/13/23	Updated certification details	TM
5	02/15/23	Update specification	TM
6	08/15/23	Certification Updated, minor edits	TM
7	10/23/23	Minor Updates, added details to troubleshooting section	TM