



**INDUSTRY LEADING EXPERTS IN
LED LIGHTING, FIRE & GAS DETECTION
PROVIDING SALES AND SUPPORT
WITH MILLIONS IN STOCK**

www.proteksc.com



**UV/IR FLAME DETECTOR
OPTIONAL HD CAMERA**

Hydrogen & Hydrocarbons
High sensitivity - up to 100ft (30m)
Built-in-Test (BIT)
Available with HD Video & Event Logger



**IR3 FLAME DETECTOR
OPTIONAL HD CAMERA**

Extreme sensitivity - up to 262ft (80m)
Ultra-fast detection mode 40 milliseconds
Built-in-Test (BIT)
Available with HD Video & Event Logger



**FLAME DETECTOR
TEST LAMP**

More than 1000 Activations between Charges
Test up to 23 feet (7M) away
Explosion Proof
Compatible with Rosemount & Spectrex



**UDM - UNIVERSAL
DISPLAY MODULE**

Singe & Dual Channel Remote Controller
Canadian Approved - Class 1 Zone 1
CI22 Installations - No Seals Required
4-20mA Pass Through Signal Output
SEC & Detcon Sensor Compatible



**H2S
GAS DETECTION**

Methanol Resistant Sensor Technology
Corrosion Resistant 316 Stainless Steel Housing
Long life Electro-chem Sensor Technology
Canadian Approved - Class 1 Zone 1



**LEL (NO-CAL) (IR)
GAS DETECTION**

Calibrations are NOT Required
Low Cost of Ownership
10 Year Warranty
Heated Optics
Low Power consumption
Canadian Approved - Class 1 Zone 1



CALIBRATION KIT

Carrying Case
Zero Calibration Gas
Span Gas
Regulator
Tygon Tubbing



REGULATORS

0.5 LPM Flow Rate
1 LPM Flow Rate
Adjustable Flow Rates
Demand Flow Regulators



CALIBRATION GAS

Stocked in Calgary
Zero Cal Gas
50% LEL Methane
25PPM H2S
50PPM H2S
Multi-Gas Combinations & More



**XEU1
3-35kW ELEC. HEATER**

CSA Approved Class 1 Zone 1
Optional built in thermostat
Voltage inputs: 208,240,480 & 600V



**XEC1
0.4-10 kW HEATER**

Convection Air Heater
Suitable for use in Hydrogen gas
Voltage inputs: 120V-600V
Class 1 Div 1, Groups IIA, IIB-H2



**XEF1E
ELECTRIC EXHAUST FAN**

Class 1 Div 2 & Class 1 Div 1
12", 16", 20" and 24" Fan sizing
1/2 Horse Power Motor
Single or Three Phase from 120- 600V



ELSR-NA

Max. temp energized: 60°C
Max. temp., de-energized: 80°C
Nominal volt.: 120VAC / 208-277 VAC
CI D1 Group B,C,D & CI D2 Group A,B,C,D



ELSR-HA

Max. temp energized: 120 °C
Max. temp., de-energized: 200 °C
Nominal volt.: 120VAC / 208-277 VAC
CI D1 Group B,C,D & CI D2 Group A,B,C,D



ELSR-SH+

Max. temp energized: 185 °C
Max. temp., de-energized: 250 °C
Nominal volt.: 120VAC / 208-277 VAC
CI D1 Group B,C,D & CI D2 Group A,B,C,D



**S550BE UV/IR
C/W REMOTE PROCESSOR**

Flame scanner viewing head for flame monitors
UV, UV/IR



**U2 SERIES
SCANNER / PROCESSOR**

All in one Processor & Scanner
Multi UV and IR Technology
Advanced Hydrogen Flame Monitoring



WATCHDOG III

Pilot and flare stack monitor
Continuous burner surveillance
Remote mounted up to 1000'



**SAFESITE LED
HIGH BAY**

11,000-41,300 Lumens
Class 1, Div. 1 & Div. 2
Certified to C22.2 No. 137-M81
10 Year Full Warranty



**PROSITE LED
FLOODLIGHT**

12,000-65,000 Lumens
Class 1, Div. 2
CSA 22.2 No. 137
10 Year Full Warranty



**SAFESITE LED
LINEAR**

3,300-9,600 Lumens
Class 1, Div. 1 & Div. 2
Light Weight
5 & 10 Year Full Warranty



**FXCSL LED LINER
LIGHTING**

Motion Detection, Battery Back-up
Available in 2', 4' & 8' Version
5 Year Warranty



**GP LED FLOOD
LIGHTING**

Slip Fitter & Yoke mount
13,000-42,000 Lumens
5 Year Warranty



**GP LED
WALL PACK**

-40 degrees C to +60 degrees C
Multi Wattage
5 Year Warranty



**EXPLOSION-PROOF
HORN**

125 dB Horn with 64 alarm tones
Class 1 & II Div 1
CSA C22.2 No 25-1966
10-year parts and labour product warranty



**EXPLOSION-PROOF
LED BEACON**

High output LED flash
Zone 1 & 2
-55 to +80 degrees C
10-year parts and labour product warranty



**ALARM HORN &
LED BEACON**

Combination Horn and LED Beacon
180 Candela / 64 Tones
cUL Approved
10-year parts and labour product warranty



Industrial Audible & Visual Signaling Devices



Industrial Strobe Warning Lights



Rate of Rise Detection



Smoke Detectors



Hinged Stanchion Poles



30' & 50' Hinged Poles & Bullhorns



Emergency Lighting & Exit Signs

AB: 403.668.6869 NE BC: 250.277.2552 SK: 306.985.0024

sales@proteksc.com

PCS-SLC-120225



FIRE & GAS DETECTION SPECIALISTS PROVIDING SALES, SUPPORT & STOCK FOR WESTERN CANADA

www.proteksc.com

+250°C SELF REG. HEAT TRACE NOW AVAILABLE



- 1 **Bus wire:**
Nickel plated copper
- 2 **Self-regulating Heating Element**
- 3 **Insulation:**
Fluoropolymer
- 4 **Protection:**
Protective braid (Cu, nickel plated)
- 5 **Outer jacket:**
Fluoropolymer



Manufactured and stocked locally in Calgary AB, eltherm Canada Inc, has partnered with Protek Safety and Controls Ltd. to provide quick delivery of mineral insulated heating cable & self regulating heating cables suitable for industrial applications, including high temperature environments, and potentially explosive atmospheres.

2 & 3 WIRE RETROFIT GAS DETECTION

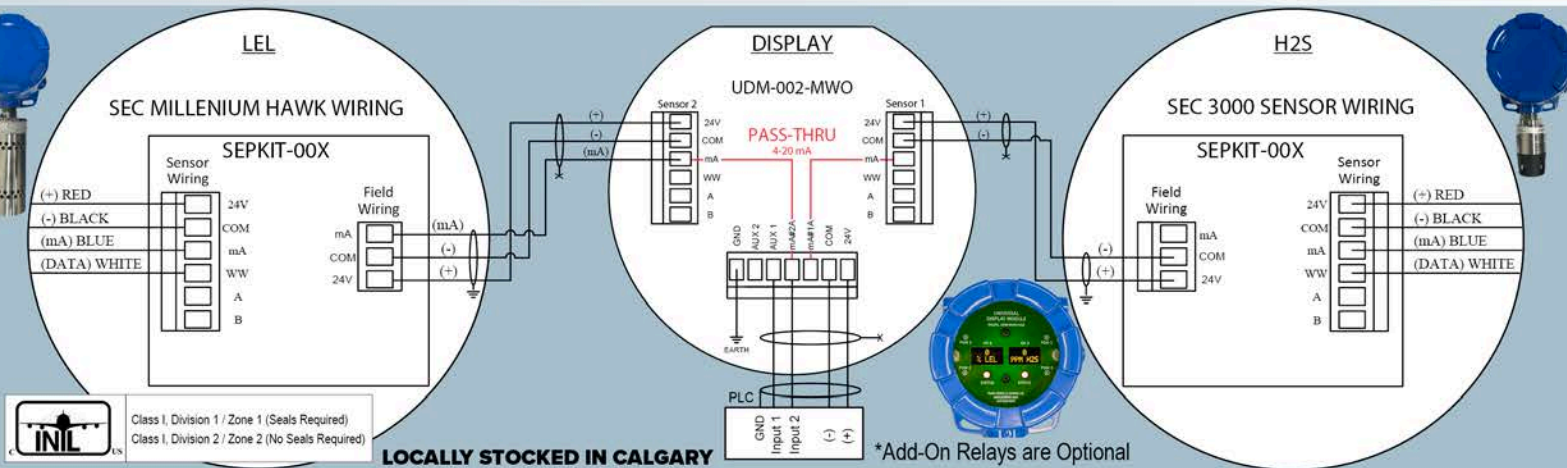

FEATURED SAFETY PRODUCT

PROTEK-UDM-MWO

Single or Dual-Channel
Universal Display
Module



- **Remote Parameter Configuration**
Full Diagnostic Information
- **Retrofit Solution for 2 or 3 Wire Gas Detectors (Separation Wiring)**
Replaces old & discounted NetSafety, General Monitors & Det Tronics
- **Smart Sensor Technology**
Pass-thru 4-20mA Output Signal
- **Universal User Friendly Interface**
Works across multiple brands
- **Mimics Gas Sensor Display**
Remote Calibration of Sensor

ABOUT PROTEK

Our primary objective is to always deliver long-term value for our customers by leveraging the strength of our partners, the dedication and expertise of our people, our stock, and the robustness of our operations.

Our promise is to always do what is right in order to exceed expectations and deliver for our customers — everytime.



AB: 403.668.6869 NE BC: 250.277.2552 SK: 306.985.0024

sales@proteksc.com

PSC-SLC-120225