



FIRE & GAS DETECTION TECHNOLOGIES INC.

User Manual



FlameSpec IR3-H2

4222 E. La Palma Ave, Anaheim, CA 92807 USA T: (+1) 714-671-8500

www.fg-detection.com · support@fg-detection.com



Information

FlameSpec-IR3-H2 Triple IR H2 Flame Detector User Guide, August 2021

Copyright © Fire & Gas Detection Technologies Inc. All rights reserved.

The owner or authorized user of a valid copy of this manual may reproduce this publication for the purpose of learning to use the specified equipment. No part of this publication may be reproduced or transmitted for commercial purposes, such as selling copies of this publication or for providing paid for support services.

The Fire & Gas Detection Technologies logo is a trademark of Fire & Gas Detection Technologies Inc., registered in the U.S. and other countries.

Every effort has been made to ensure that the information in this manual is accurate. However, Fire & Gas Detection Technologies Inc. is not responsible for any inaccuracy or omission in this document. The information in this document is subject to change without notice.

Legal Notice

Hardware, software or documentation is forbidden to reproduced, transmitted, transcribed, stored in a retrieval system or translated into any language or computer language, in any form or by any means.

While great efforts have been made to assure the accuracy and clarity of this document, FIRE & GAS DETECTION TECHNOLOGIES INC. assumes no liability resulting from any omissions in this document, or from misuse of the information obtained herein. The information in this document has been carefully checked and is believed to be entirely reliable with all of the necessary information included.

FIRE & GAS DETECTION TECHNOLOGIES INC. reserves the right to make changes to any products described herein to improve reliability, function, or design, and reserves the right to revise this document and make changes from time to time in content hereof with no obligation to notify any persons of revisions or changes. FIRE & GAS DETECTION TECHNOLOGIES INC does not assume any liability arising out of the application or any use of any product or circuit described herein; neither does it convey license under its patent rights or the rights of others.

Table of Contents

1. Introduction	1
1.1 Features	1
1.2 Model Number Description	2
1.3 Internal tests	2
1.4 Product Overview	3
1.5 Accessories	4
2. Installation	7
2.1 General Considerations.....	7
2.2 Preparations for Installation.....	10
2.3 Required Tools.....	10
2.4 Certification Instructions.....	10
2.5 Mounting the Tilt Mount.....	11
2.6 Mounting the detector.....	13
2.7 Electrical Wiring.....	14
2.8 Current Output (0-20mA) Wiring	16
2.9 4 Wire Relay Connection	18
2.10 RS-485 Communication Network.....	18
2.11 Cabling Recommendations	19
2.12 Earth/Ground Regime	19
3. Configuration options	20
3.1 Sensitivity.....	22
3.2 Ultra-Fast Detection.....	22
3.3 Alarm Delay	22
3.4 Alarm Latch	22
3.5 Enable Pre-Alarm 0-20mA	22
3.6 Enable dirty window warning 0-20mA	23
3.7 Auxiliary Relay	23

3.8	Window Heater	23
3.9	Modbus Address	23
3.10	Manual BIT – Alarm Output Test (Full Loop test)	23
4.	Operation	24
4.1	Output Signals	24
4.2	Testing.....	25
4.3	Flame Simulator.....	25
5	Maintenance	25
5.1	Cleaning Procedure	26
6	Troubleshooting.....	26
7	Servicing.....	27
8	FGD Communicator Software	27
9	Specifications.....	28
9.1	Fire Detection	28
9.2	Electrical Specifications	28
9.3	Outputs	28
9.4	Mechanical Specifications	29
9.5	Environmental Specifications	29
9.6	Product Labeling	30
9.7	Approvals	32
9.8	Electromagnetic Compatibility	32
10	Performance.....	33
10.1	FLS-IR3-H2-ASX1 (Standard Mode).....	33
10.2	False Alarm Immunity	34
11	Ordering Information.....	35
12	Warranty.....	36
	Appendix A.....	37

List of Figures

Figure 1 - Front view of the FLS-IR3-H2	3
Figure 2 - Rear view of the FLS-IR3-H2	3
Figure 3 - Tilt mount.....	4
Figure 4 - Weather COVER	4
Figure 5 - Pole Mount	5
Figure 6 - Air Shield.....	5
Figure 7 - Flame Simulator Kit.....	6
Figure 8 - FLS-FSIM-IR3-H2 Flame Simulator Front View	6
Figure 9 - Horizontal Field of View	8
Figure 10 - Vertical Field of View.....	8
Figure 11: Tilt Mount Base - Front View.....	12
Figure 12: Tilt mount base – Side View.....	12
Figure 13 - Detector on Tilt Mount – Side View.....	13
Figure 14 – Terminal View	14
Figure 15 – Source 4-Wire Scheme	16
Figure 16 – Sink 4-Wire Scheme	16
Figure 17 – Source 3-Wire Scheme.....	17
Figure 18 – Sink 3-Wire Scheme	17
Figure 19 - 4 Wire Relay Connection.....	18
Figure 20: RS-485 Networking	19

List of Tables

Table 1: Terminal connections.....	15
Table 2: Detector Configuration Options.....	21
Table 3: Sensitivity levels	22
Table 4: Output Signals.....	24

1. Introduction

The FlameSpec-IR3-H2 flame detector will detect hydrogen and other “energy transition” fires quickly allowing actions to be initiated to minimize the extend of the fire. The detector addresses slow growing fires as well as fast eruptions of fire using improved IR3 technology. The detector operates in all weather and light conditions.

These features, along with a built-in event logger, provide additional means to study the cause and development of fire events.

The detector is certified for use in hazardous area locations; it may also be used in other areas not classified as hazardous. The two cable/conduit entries either side of the lower part of the detector housing are for connecting power and outputs to associated signaling equipment.

During normal operation, the flame detector performs self-tests of its optics, electronics, and software. These include a periodic BIT (Built-In-Test) in which the sensors and window cleanliness are tested.

1.1 Features

- **High sensitivity** - up to 100ft (30m)
- **Ultra-fast detection mode** - detection within 40 milliseconds for fireballs or explosions.
- **Detection of “energy transition” flames, like hydrogen, methane, syngas, and methanol**
- **Extreme sensitivity:** Up to 100 ft. (30m) for a 32” plume, 1.5secs response
- **Option: Improved speed of response for standard fires** - (0.5s) for enclosed space protection, like spray paint booths or printing presses
- **Built-in-Test (BIT)** - Automatic and manual self-test of window cleanliness and detector operation.
- **Window heater** to avoid condensation and icing.
- **Tilt mounting bracket** for accurate detector positioning.

1.2 Model Number Description

Model No are defined as follows:

FLS-IR3-H2 - A S X X

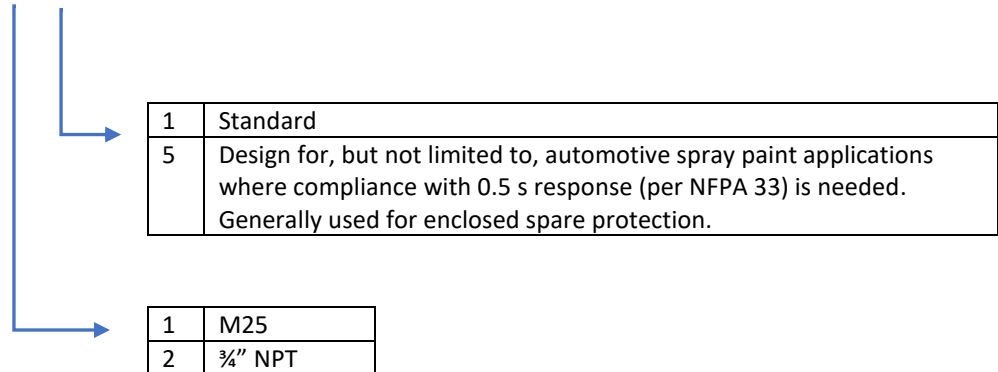

1.2.1 Enhanced performance options

Option 5: Design for, but not limited to, enclosed space protection like automotive spray paint applications where compliance with 0.5 s response (per NFPA 33) is needed

1.3 Internal tests

During normal operation, the flame detector performs self-tests of its optics, electronics and software. These include a periodic BIT (Built-In-Test) in which the sensors and window cleanliness are tested. Any detected fault is indicated as shown in Table 4 (in section 4). During "Dirty Window" fault the detection sensitivity is significantly reduced, while "Fault" refers to critical faults which totally prevent flame detection.

1.4 Product Overview



FIGURE 1 - FRONT VIEW OF THE FLS-IR3-H2



FIGURE 2 - REAR VIEW OF THE FLS-IR3-H2

1.5 Accessories

1.5.1 Mounting Bracket

The detector should be mounted using the stainless-steel tilt mount part number FLS-TMO-S01. This allows the detector to be securely attached to a wall, pole or other solid surface using appropriate fixings. See section 2.5 and 2.6 for further details.



FIGURE 3 - TILT MOUNT

1.5.2 Weather Cover

The weather cover P/N FLS-WCO-S01 protect the detector from extreme weather conditions such as heat, rain and snow



FIGURE 4 - WEATHER COVER

1.5.3 Pole mount

The pole mount enables the detectors to be installed with its tilt mount brackets. The pole mount kit we supply are suitable for 2-inch or 3-inch poles. Part number FLS-PMA-S23.



FIGURE 5 - POLE MOUNT

1.5.4 Air shield

The air shield P/N FLS-ASD-S01 allows installation of flame detectors in harsh weather conditions where they may be exposed to dust, sand, and other particulate matter. The connection point can be mounted in the 3, 9 or 12 o'clock locations.

- Air pressure source: Clean, dry, and oil-free air
- Pressure: 2-3 bar /30-45 psi
- Fitting: 7/16" —20UNF-2A
- Operation temperature: -55°C to +85°C / -67°F to +185°F

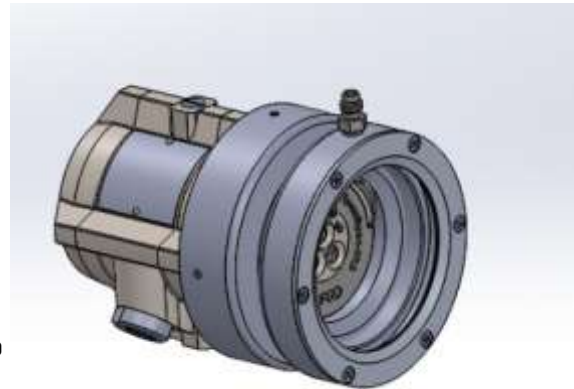

FIGURE 6 - AIR SHIELD

1.5.5 Flame Simulator

The FLS-IR3-H2 may be tested using the FLS-FSIM-IR3-H2-KIT. The FlameSpec flame simulator family provides a fast and convenient means of periodically testing the detector and control system end-to-end. Maintenance costs can be reduced as the detectors can be tested in situ without needing a hot work permit.

FlameSpec Flame Simulators emit IR radiation in a special electromagnetic radiation pattern which simulates a hydrogen fire to the detectors. The simulators are lightweight, easy to use, with testing distances of up to 23 ft. (7m) and capable of more than 1000 activations between battery charging. FlameSpec Flame Simulators are ATEX approved for use in hazardous Zone 1, Zone 2, Zone 11, Zone 22 areas.

Each simulator kit contains a carrying case, simulator, carrying strap, battery charger, user manual, Allen key and a tool for removing the simulator rear cover.



FIGURE 7 - FLAME SIMULATOR KIT



FIGURE 8 - FLS-FSIM-IR3-H2 FLAME SIMULATOR FRONT VIEW

2. Installation

This chapter does not attempt to cover all of the standard practices and codes of installation. Rather, it emphasizes specific points of consideration and provides some general rules for qualified personnel. You must always observe special safety precautions.

2.1 General Considerations

 This section includes important information.

- To help obtain optimal performance, the detector should be aimed toward the center of the hazard or area to be monitored and protected ("detection zone") and have, to the extent that is required, an unobstructed view of the protected area. Whenever possible, the detector face should be tilted (aimed) down at an angle to prevent the accumulation of dust and dirt.
- Do not start an installation until the performance target, system configuration, installation location and coverage considerations have been defined by the responsible person.

To ensure optimal performance the following guidelines should be addressed:

Sensitivity

To determine the sensitivity level, the following points should be considered:

- The size of the fire to be detected at the determined distance.
- The type of flammable fuel.
- Potential sources of false alarms that may be present (e.g., naked flames, hot process).

Spacing and Location

Consider the following factors when determining the number of detectors and their locations in the protected area:

- The size and shape of the protected area
- The nature of the hazards, including materials stored or used and the protected objects
- The sensitivity of the detectors
- If there are any obstructed lines of sight
- The field of view of the detectors (See Figure 9 and Figure 10)

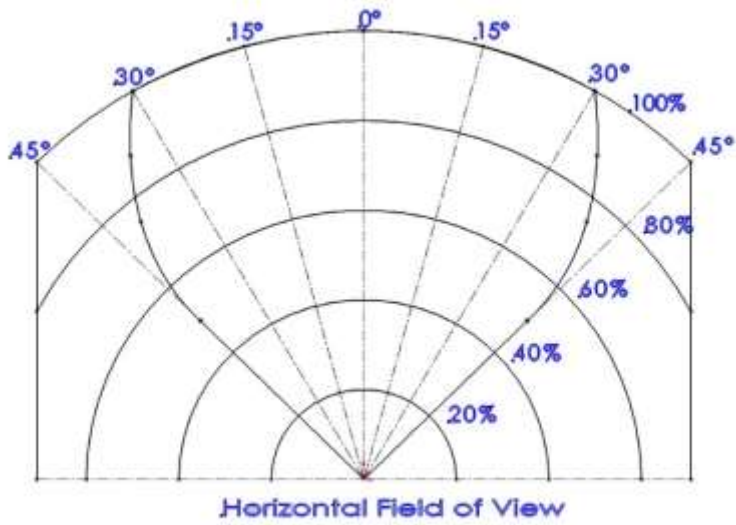

FIGURE 9 - HORIZONTAL FIELD OF VIEW

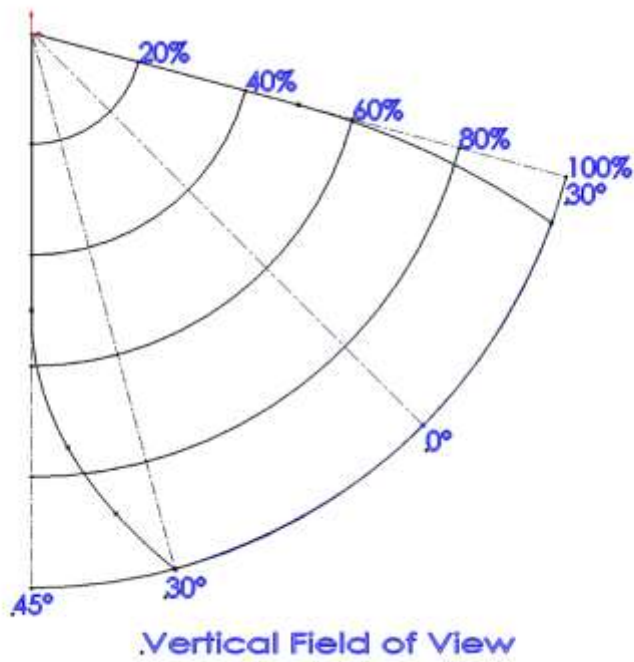

FIGURE 10 - VERTICAL FIELD OF VIEW

Environment

- Environmental conditions including but not limited to dust, snow or rain can reduce the detectors sensitivity and require additional consideration.

Hot Work

- Arc welding should not be performed within 15 ft. (5m) of the detector. It is recommended that the system be inhibited during welding operations in situations where the possibility of a false alarm cannot be tolerated.
- Gas welding requires a system inhibit, since the gas torch is an actual fire.
- Arc welding rods can contain organic binder materials in the flux that burn during the welding operation and are detectable by the device.
- Welding rods with clay binders do not burn and should not be detected. However, a system inhibit is always recommended, since the material being welded may be contaminated with organic substances (paint, oil, etc.) that will burn and may be of the size that should be detected.

2.2 Preparations for Installation

The installation must comply with national and local regulations and standards applicable to flame detectors (e.g., NFPA 72) and all local and common engineering practices. It is recommended to consult with the authority having jurisdiction.

Prior to installation:

- Make sure that you have all the components and tools required to complete the detector installation readily available before beginning installation. In cases where you cannot complete the installation in a single session, secure and seal the detectors and conduits before leaving the site.
- Use color-coded conductors or suitable wire markings or labels for the wiring. You may use 14 to 17 AWG (2.5mm² to 1.0mm²) multi-strand wires for the site wiring. The selection of wire gauge should be based on the number of detectors used on the same line and the distance from the control unit, in compliance with specifications.
- Individually screen twisted pair cable is recommended for RS485 terminals.
- Use suitably rating wire for the application certification and temperatures.

2.3 Required Tools

The detector can be installed using the following tools:

Tool	Function
Hex. KEY 6 mm	Vertical alignment
Hex. KEY 10 mm	Horizontal alignment
Wrench 13 mm	Mounting the detector
Flat Screwdriver 6 mm	Ground screw connection
Flat screwdriver 3.5mm	Terminal connection

2.4 Certification Instructions

Warnings

- Do not open the detector, even when isolated, when flammable atmosphere present.
- The equipment may be used in hazardous areas with flammable gasses and vapors with apparatus groups IIC, IIB and IIA and with temperature classes T1, T2, T3, T4 and T5. See details of the explosion proof approvals in section 0.
- The equipment is certified for use in ambient temperatures in the range of -67°F to +167°F (-55°C to +75°C) or -67°F to +185°F (-55°C to +85°C) and should not be used in temperatures outside this range.
- Installation shall be carried out in accordance with the applicable code of practice by suitably trained personnel.

- Inspection and maintenance of this equipment shall be carried out by suitably trained personnel in accordance with the applicable code of practice.
- If the equipment is likely to come into contact with corrosive and other harsh substances, consult with the relevant technical persons to take suitable precautions to prevent the detector from being adversely affected, thus ensuring that the type of protection is not compromised.
- Harsh substances: For example, acidic liquids, gases, or solvents that may attack the windows, metals, seals or polymeric materials.
- Suitable precautions: For example, regular checks as part of routine inspections or establishing from the material's data sheet that it is resistant to specific chemicals.

Specific conditions for use

- The equipment is not intended to be repaired by the user. Repair of this equipment shall be carried out by the manufacturer in accordance with the applicable code of practice.
- The flame paths are not intended for repair. Contact the manufacturer if the flame paths are damaged.
- Consult the manufacturer for genuine replacement cover and housing to connection box fasteners. M6x1x18 Hexagonal Socket head fasteners with a minimum of ISO 4762 Grade A4 Class 80 are acceptable alternatives.
- One suitably certified stopping plug is supplied with the detector.
- The external earthing connection consists of cable lug with M5x10 stainless steel screw, the terminals is suitable for connection of a wire of at least 4mm² / 12AWG.
- The internal terminals are suitable for connection of a wire equal to or greater than the power input wiring and at a minimum of 1mm² / 17AWG conductor.

2.5 Mounting the Tilt Mount

The tilt mount enables the detector to be rotated up to 45 degrees (horizontal/vertical) in all directions. The following installation instructions show how to use it to support the detector from below (the preferred method). However, with a designated adapter the tilt mount can hold the

detector from above. Contact FGD for more details on mounts suitable for retro fit of existing installations.

To install the tilt mount:

- a) Mount the tilt mount base (Figure 11: Tilt Mount Base - Front View) to a solid structure using four suitable fixings through the four 7mm (0.28") diameter holes. Four captive screws with spring washers are provided in the tilt mount.

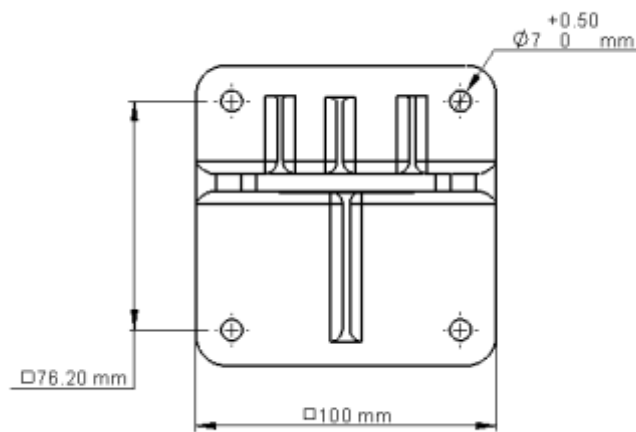

Figure 11: Tilt Mount Base - Front View

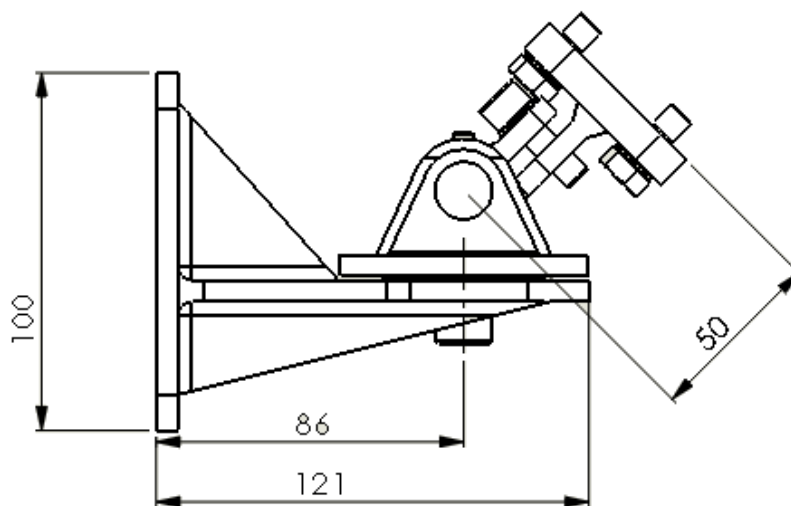

Figure 12: Tilt mount base – Side View

2.6 Mounting the detector

Referring to Figure 13 use the following steps to connect the detector to the tilt mount:

- a) Place the detector, with its cable/conduit entries pointing down, on the holding plate of the tilt mount (item 2).
- b) Secure the detector to the plate using the two hex screws and spring lock washers (items 3 and 4).
- c) Loosen the locking screws (Items 5 and 6) in such a way that enables you to rotate the detector.
- d) Point the detector towards the detection area and make certain that the view of the area is unobstructed.
- e) Secure the detector in that position by tightening the locking screws (Items 5 and 6) on the tilt mount. (Make sure the detector is pointing in the correct direction).

The detector is now correctly mounted, aligned and ready for electrical connection. Please refer to section 2.7 for wiring instructions, and section 3 for a description of the detector's configuration settings.

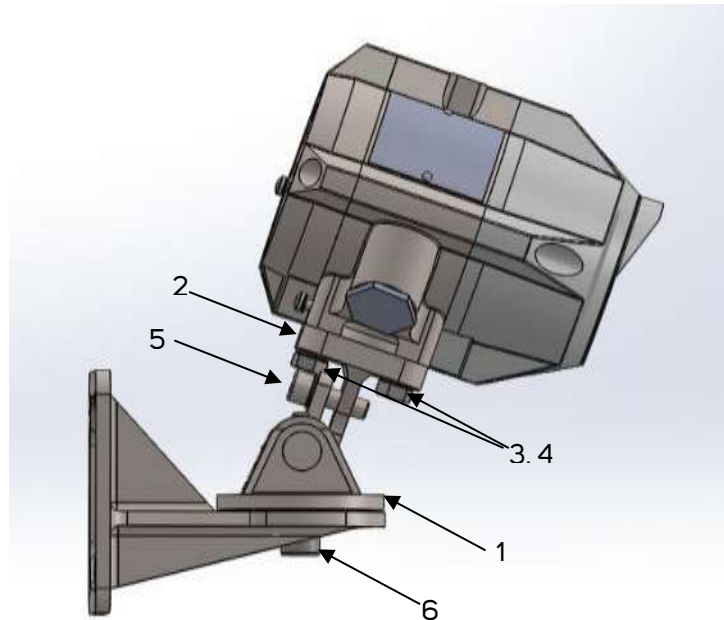

FIGURE 13 - DETECTOR ON TILT MOUNT – SIDE VIEW

ITEM NO.	ITEM NAME
1	TILT MOUNT ASSEMBLY
2	HOLDING PLATE
3,4	MOUNTING HEX SCREWS M8 AND LOCK WASHERS
5	HEX SOCKET LOCKING SCREW M8
6	HEX SOCKET LOCKING SCREW M12

2.7 Electrical Wiring

⚠ Warning

- The sensor module in the front half of the detector contains no serviceable components and should never be opened. Opening will invalidate the warranty of the detector. The terminal compartment at the back is the only part of the housing that should be opened by the user.
- The detector has 16 screw terminals as shown in the following figure and table:

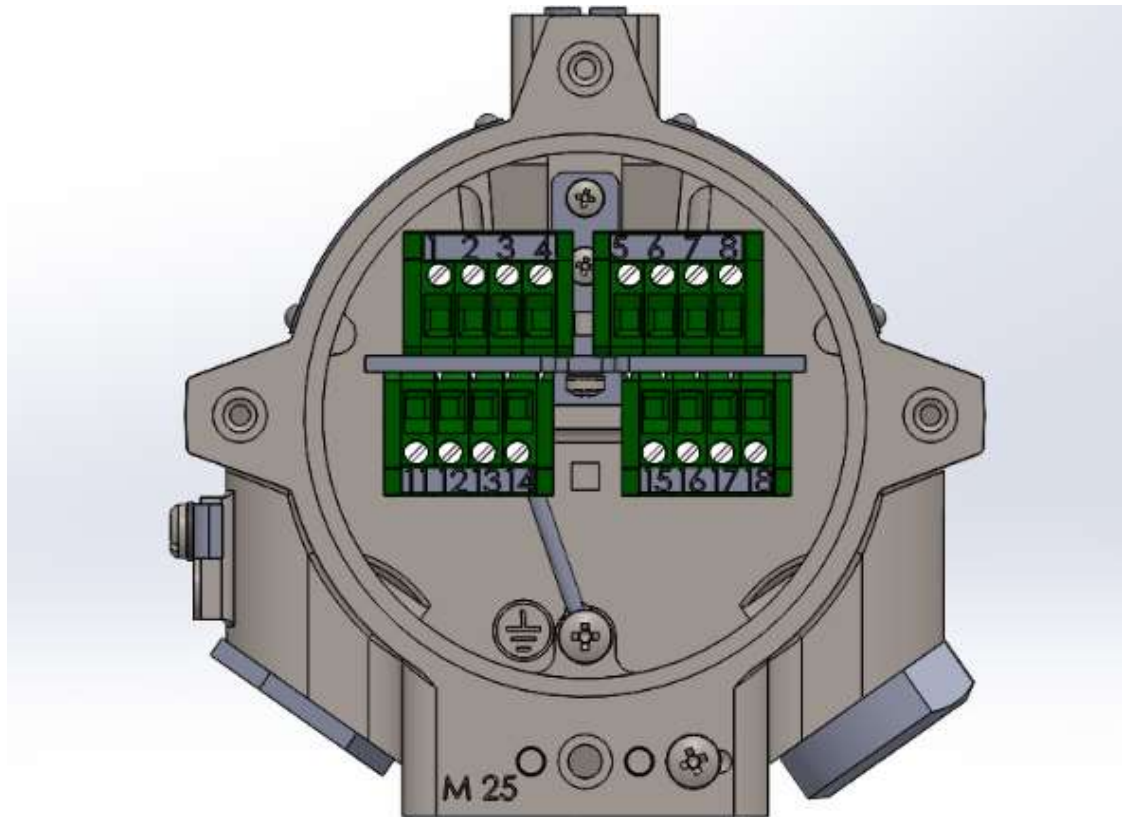

FIGURE 14 – TERMINAL VIEW

TABLE 1: TERMINAL CONNECTIONS

Pin #	Function	Description
Ground	Ground (earth)	Connected to a screw on the housing exterior.
1	24 VDC (+)	Power supply (18-32 VDC)
2	24 VDC (-)	Power supply return (0V)
3	0-20mA+ (In)	This output is used for analog 0-20 mA current output
4	0-20mA- (out)	
5	Fault Relay	A normally open SPST contact relay, that is energized (closed) when the detector is in normal operation and opens under fault condition.
6	Fault Relay COM	
7	Alarm Relay (NO)	A normally open SPST contact relay, that is open in normal operation, and closed when fire is detected. This relay can be configured to latch as described in section (3.4).
8	Alarm Relay COM	
11	24 VDC (+)	Power supply (18-32 VDC)
12	24 VDC (-)	Power supply return (0V)
13	Manual BIT activation	The manual BIT (built-in test) can be initiated by momentarily connecting this terminal and one of the "24 VDC (-)" terminals (2 or 12). See 3.10 Manual BIT – Alarm Output Test for more details.
14	Shield	This terminal should be left connected to the housing internal ground screw.
15	RS 485 (+)	RS-485 Modbus communication (also used by the "FGD Communicator" software)
16	RS485 (-)	
17	Auxiliary Relay NO	A normally open SPST contact relay, that is open in normal operation, and closed according the selected configuration
18	Auxiliary Relay COM	

2.8 Current Output (0-20mA) Wiring

The detector's 0-20mA current output can act as both a source or a sink transmitter and can be 3-wire or 4-wire connected.

The following drawing shows how to wire the detector to act as a current source isolated transmitter (4-wire connection):

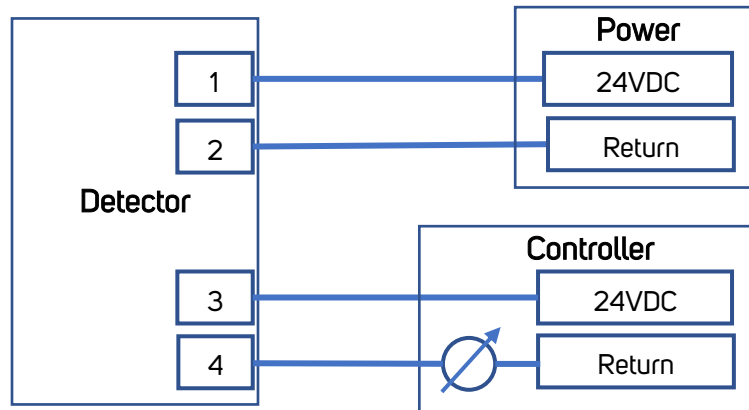

FIGURE 15 – SOURCE 4-WIRE SCHEME

The following drawing shows how to wire the detector to act as a current sink isolated transmitter (4-wire connection):

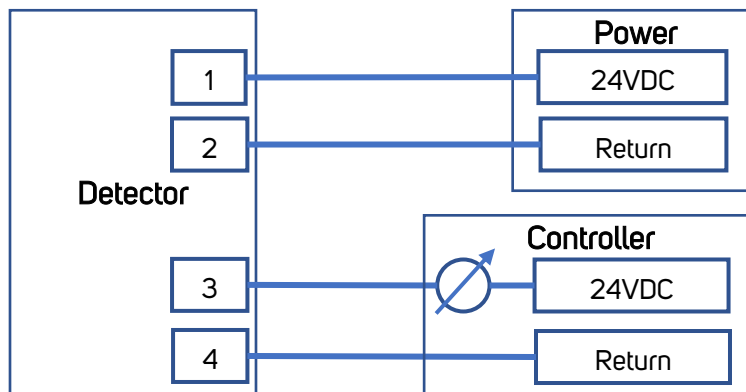

FIGURE 16 – SINK 4-WIRE SCHEME

The following drawing shows how to wire the detector to act as a current source non-isolated transmitter (3-wire connection):

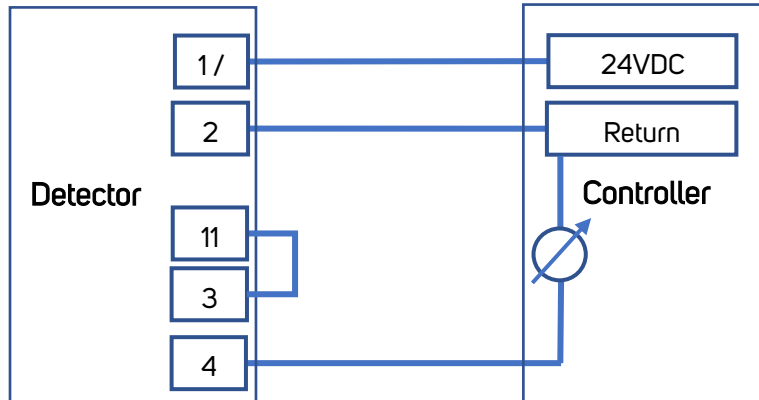

FIGURE 17 – SOURCE 3-WIRE SCHEME

Note: Link between 3 and 11 to be wired on site

The following drawing shows how to wire the detector to act as a current sink non-isolated transmitter (3-wire connection):

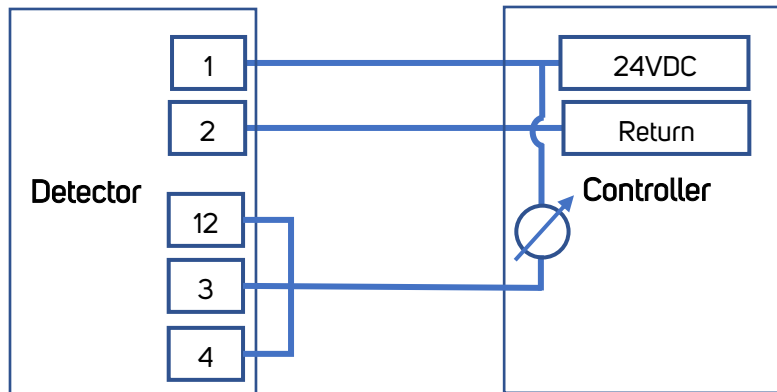

FIGURE 18 – SINK 3-WIRE SCHEME

Note: Link between 4 and 12 to be wired on site

2.9 4 Wire Relay Connection

This wiring option uses the fault and alarm relay and are connected to fire alarm panels. This connection allows to connect several detectors on 4 wires in a single loop. On the last detector there is a connected EOL resistor in the connection box. The value of the resistor depends on the control panel specification.

The number of detectors in a single loop depends on the control panels power supply capacity and length on wire width.

In fault condition, the fault relay will open the contact. The control panel will see an open loop and will report a fault.

In alarm condition, the alarm relay will close the contact and short the loop. With this configuration, the panel does know which detector in the loop caused the alarm or fault. See figure below.

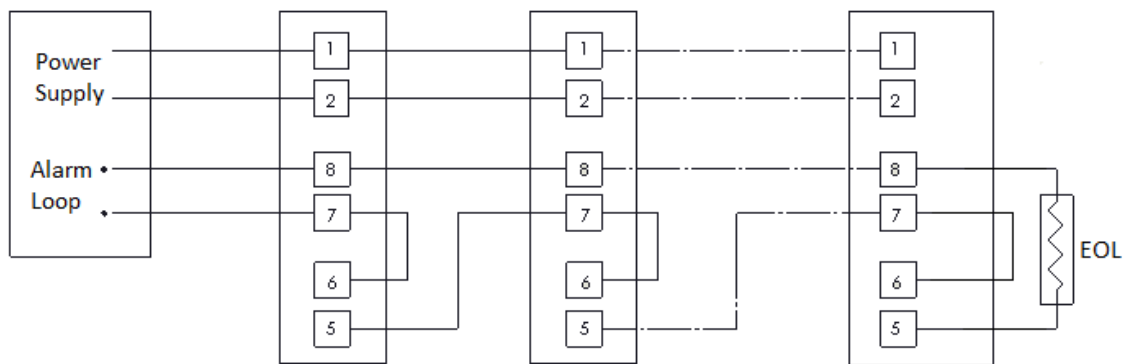

FIGURE 19 - 4 WIRE RELAY CONNECTION

2.10 RS-485 Communication Network

Using the RS-485 network capability of the detector and communicator software, it is possible to connect up to 32 detectors in an addressable system with only 4 wires (2 for power and 2 for communication). Using repeaters, the number of detectors can be much larger (32 detectors for

each repeater) up to 247 on the same 4 wires. Using the RS-485 network, it is possible to read each detector's status (fault, alarm) and to initiate a BIT to each detector individually.

The detector communicates via RS-485 with a Modbus RTU compatible protocol. For more details on the communication protocol, please see manual F100P0013

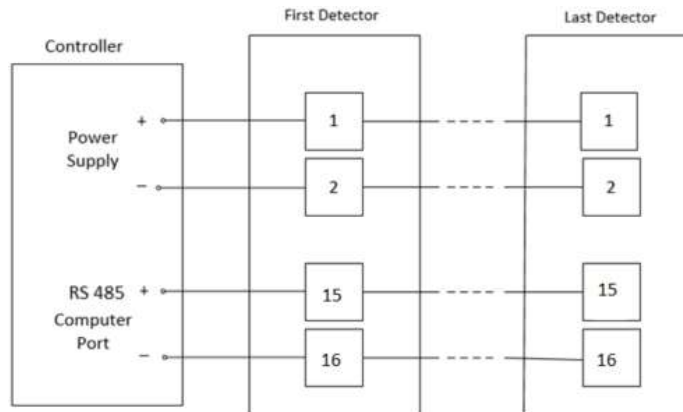

Figure 20: RS-485 Networking

2.11 Cabling Recommendations

The cable used should be appropriate for the hazardous area classification and meet local, national and company regulations.

In order to comply to EMC regulations, the cable must be shielded and the detector grounded.

The use of industrial grade, suitably armored field cable is recommended. When using HART® communications, there are some additional considerations. In particular, low capacitance cable should be used. Further detailed information can be found at the HART® Communication Foundation's website www.hartcomm.org.

2.12 Earth/Ground Regime

Any earthing regime employed must avoid earth loops. The following information is provided to assist with proper earthing of the detector

- There is an earthing point on the outside of the detector enclosure for connection to Electrical ground

2.12.1 General recommendations

- In general, correctly engineered star earthing arrangements minimize earth current crosstalk and noise, improving the reliability and performance of instrumentation.

- The use of a single, screened / shielded cable for each field device ensures good screening / shielding and reduces crosstalk.

2.12.2 Field Cabling

- The entire length of the field cabling connected to a unit should be screened / shielded. The screen / shield should be connected to a low noise instrument earth at one end.
- The screens / shields of field cabling must not be connected in a manner that creates earth loops or that will result in the screens / shields carrying large currents from heavy plant or equipment.

2.12.3 Interference and noise

- Electrical equipment connected to the system should comply with applicable national or international EMC standards.
- Ideally, the 24 V supply reaching units should be free from large transients, fluctuations or high frequency noise.
- In order to reduce the likelihood of radio frequency interference affecting the operation of units it is recommended that neither units nor their cabling are installed in close proximity to the antennae of high-powered radio, radar or satellite communication equipment.

3. Configuration options

Some functions of the detector can be configured using an RS-485 modem connected to a computer with the "FGD communicator" software. For details of how to download the software please contact technical support on: (+1) 714-671-8500 or via email at support@fg-detection.com

These configuration options are listed in the following table along with their factory default values.

TABLE 2: DETECTOR CONFIGURATION OPTIONS

Function	Options	Default Setting
Sensitivity	Very low, Low, Medium, High, Extreme	Medium
Ultra-fast detection	Disabled, Enabled	Disabled
Alarm Delay	0, 5, 10, 20 or 30 seconds	0 seconds (no delay)
Alarm Latch	Disabled, Enabled	Disabled
Enable Pre-Alarm 0-20mA	Disabled, Enabled	Disabled
Enable dirty window warning 0-20mA	Disabled, Enabled	Disabled
Aux. Relay	Alarm, Pre-Alarm, Dirty Window Warning	Alarm
Window Heater	Disabled, Enabled	Enabled
Modbus address	1 – 247	1
Manual BIT – Alarm Output Test	Disabled, Enabled	Disabled

- Note: Medium, Default, sensitivity setting allows detection of a 32-in Plume hydrogen flame at a distance of 66ft (20m).

3.1 Sensitivity

The detector can be configured to one of five sensitivity levels: very low, low, medium, high and extreme. The following table lists for each sensitivity setting the maximum distance, in which a standard H₂ fire¹ would be reliably detected.

TABLE 3: SENSITIVITY LEVELS

Sensitivity level	Detection distance in feet (meters)
Very Low	16 (5)
Low	33 (10)
Medium	66 (20)
High	98 (30)
Extreme	98 (30)

Further details about the response characteristics of the detector at the different sensitivity settings and fuel types can be found in section 10.

3.2 Ultra-Fast Detection

The ultra-fast detection feature allows detection of fireballs and explosions at 40 milliseconds. If enabled, this feature is independent of other detection algorithms and alarm delays.

3.3 Alarm Delay

When a fire is detected, the detector delays the execution of the alarm outputs by the configured time period. After this time delay, the detector re-evaluates the situation. If a fire is still detected the alarm outputs are activated.

3.4 Alarm Latch

If alarm latch is enabled, the detector outputs will remain active even after a fire is no longer detected. To reset the detector outputs, the detector must be power cycled or a manual BIT initiated.

3.5 Enable Pre-Alarm 0-20mA

If the Pre-Alarm is enabled and Alarm Delay is greater than 0, the detector 0-20mA output will be 16mA and the red LED will blink in case of a pre-alarm fire condition.

¹ A standard fire is defined as a 32-in Plume of H₂ fire, with maximum wind speed of 6.5 ft/s (2 m/s).

3.6 Enable dirty window warning 0-20mA

If enabled, this feature assists predictive maintenance by indicating an alert when the BIT signal has reduced by 75% of the value needed to trigger a BIT fault failure. When activated, the milliampere output will drop to 3mA and the LED will remain steady green, it should be noted that a fire signal will override the dirty window warning. A process variable of optical contamination (BIT signal level) is accessible via HART and / or MODBUS. The value of the field ranges from 0 (clean) to 100% (BIT fault).

3.7 Auxiliary Relay

The Aux relay can be set to operate in parallel to alarm relay, at pre-alarm level or on “dirty window warning”.

3.8 Window Heater

The detector is equipped with a heater to prevent condensation and icing on the window. If enabled, the heater is operated automatically depending on temperature.

3.9 Modbus Address

The detector can communicate with the FGD communicator software using a Modbus RTU compatible protocol on RS-485. This protocol allows for a network of detectors to be connected, each with a unique Modbus address. The address of the detector can be set to any value in the range 1–247.

3.10 Manual BIT – Alarm Output Test (Full Loop test)

When enabled, the alarm outputs (Relay and mA) are activated when a **Manual BIT** is initiated. See section 4.2 for details.



Make sure to disable all fire extinguishing actions or alarms connected to the detector when the manual BIT is initiated and the “Manual BIT – Alarm Output Test” is enabled as the Manual BIT will set the 0-20mA terminal to 20mA and close the alarm relay and auxiliary relay if configured.

4. Operation

After power up, the LED on the front of the detector flashes Yellow indicating the startup routine has begun. After approximately 30 seconds, if the startup is successful, the LED turns green, the 0-20mA output goes to 4mA and the fault relay is closed.

Detector configuration settings can be changed as described in section 3.

To restart the detector, cycle the power.

4.1 Output Signals

The detector has the following output signals:

- Current output (0-20mA) with HART 7
- Relays (Fault, Alarm and Auxiliary)
- Modbus RS-485
- Tri-color status LED

TABLE 4: OUTPUT SIGNALS

		State				
State	Output	0 – 20mA	Fault Relay (NO)	Alarm Relay NO	Aux Relay (NO)	LED
	Startup	1mA	Open	Open	Open	Flashing Yellow
	Fault	1mA	Open	Open	Open	Flashing Yellow
	BIT Fault	2mA	Open	Open	Open	Yellow
	Dirty Window Warning	3mA (1)	Closed	Open	Closed (2)	Green
	Normal	4mA	Closed	Open	Open	Green
	Pre Alarm	16mA (3)	Closed	Open	Closed (4)	Flashing red
	Fire Alarm	20mA	Closed	Closed	Closed	Red

Notes:

1 – 3mA when "Enable dirty window warning 0-20mA" enabled. 4mA when "Enable dirty window warning 0-20mA" disabled.

2 – Closed when "Aux Relay" set to "Dirty Window Warning".

3 – 16mA when "Enable Pre-Alarm 0-20mA" enabled. 4mA when "Enable Pre-Alarm 0-20mA" disabled.

4 – Closed when "Aux Relay" set to "pre-alarm".

4.2 Testing

The detector has a Built-In-Test (BIT) capability to ensure proper operation and to indicate when the windows are dirty. The BIT process runs automatically at startup and periodically during the operation of the detector. The BIT can also be initiated manually by connecting the "Manual BIT" terminal and the "24 VDC (-)" terminal for one second (see Table 1) or by using the FGD communicator software (connected through RS-485).

In case of "Dirty Window" warning the detector may still detect flames but at a lower sensitivity.

When "Manual BIT – Alarm Output Test" feature is enabled (default disabled) using the FGD Communicator Software, a successful Manual BIT will activate the following alarm outputs for a few seconds:

1. The LED in the front of the detector will turn red.
2. The 0-20mA current output will be set to 20mA.
3. The alarm relay will close.

Warning

- When the manual BIT is initiated and "Manual BIT – Alarm Output Test" is enabled using the Communicator Software, the current output of the detector will go to 20mA and the alarm relay will activate. Ensure all fire extinguishing actions or alarms connected to the detector are disabled.

4.3 Flame Simulator

Flame simulators are often used by industry to perform detector testing during installation and periodic end to end testing of a flame detector alarm system. Refer to the FlameSpec Flame simulator manual F300V0020 for full instructions.

5 Maintenance

After powering up, the detector should work maintenance free. Regular checks should be in the form of a physical inspection and to periodically ensure the optical surfaces are clean (windows and reflective mirror). It is also recommended to perform a function test annually or in line with local requirements, whichever is the sooner.

Warning

- The sensor module in the front half of the detector contains no serviceable components and should never be opened. Opening the front of the detector will invalidate the detector warranty. The terminal compartment at the rear of the detector is the only part of the housing that should be opened by the user.

5.1 Cleaning Procedure

To clean the detector:

- a) Disconnect the power to the unit and disable/inhibit any extinguishing equipment that is connected to the unit.
- b) Use water and detergent to clean the detector windows and underside of the reflector. Rinse with a soft cloth, cotton swab, or tissue.
- c) Where dust, dirt or moisture accumulates on the window, first clean the window with a soft optical cloth and detergent, and then rinse with a clean soft cloth, cotton swab, or tissue. If contamination continues to be an issue consider using the air shield.

6 Troubleshooting

Use the table below to help troubleshoot any detector operational issues.

Detector Status	Possible Cause	Corrective Action
LEDs Off Fault Relay is open Current output at 0mA	No power to the unit	<ul style="list-style-type: none"> • Check that the power (18-vDC – 32vDC is available to the detector. • Check power polarity. • Check wiring in the detector.
Yellow LED constantly on Fault Relay is open Current output at 0mA	Power problems	Check the voltage between the “24VDC (+)” and “24VDC (-)” terminals to verify that it is in the allowed range (see section 9.2)
Yellow LED constantly on Fault Relay is open 0–20mA at 2mA	BIT Fault	Clean detector window and underside of reflector. Power cycle the detector (turn the power off and then back on) or initiate a manual BIT test.
Green LED constantly on Fault Relay is closed 0–20mA at 3mA	Dirty Window Warning	Clean detector window. Restart the detector (by turning the power off and then back on).
Red LED constantly on	Detector is in alarm latch mode	Power cycle the detector (turn the power off and then back on) or initiate a manual BIT.
Alarm Relay closed and current output is at 20mA	Detector is exposed to a flame	<ul style="list-style-type: none"> • Check cause of alarm. • If caused by “friendly fire”, re-position the detector so that it is not affected by it.

7 Servicing

The detector contains no user serviceable parts. In the event the detector has been damaged or is deemed to not be working properly, it should be returned to the manufacturer for repair. For technical assistance and to request a returns authorization number contact technical support on: (+1) 714-671-8500 or via email at support@fg-detection.com. Refer to the detector warranty statement in section 12.

8 FGD Communicator Software

The FGD Communicator software can be used to configure and monitor the FlameSpec-IR3-H2 flame detector. The software communicates using Modbus over an RS-485 port to the detector. Modbus commands enable the user to configure parameters and monitor the status of the detector. For details of how to download the software and be sent a copy of the manual please contact technical support on: (+1) 714-671-8500 or via email at support@fg-detection.com.

9 Specifications

9.1 Fire Detection

- Detection time and distance:
 - 40ms - for fast fire burst or explosion
 - 1.5s - for 32" (0.8m) hydrogen fire at 0–66ft. (0–20m)
 - 4s - for 32" (0.8m) hydrogen fire at 66–100ft. (20–30m)
- Field of view: 90° Horizontal, 75° Vertical
- Time Delay: 0-30 seconds (adjustable)
- Built-in test: Automatic and Manual

9.2 Electrical Specifications

- Operating Voltage: 24 VDC nominal (18-32 VDC)
- Current Consumption:
 - Standby 120mA
 - Maximum 180mA all systems in operation (including window heater)
- Cable Entries: 2x conduit entries 3/4" NPT or M25, with one entry plugged with a suitably certified stopper.
- Wiring: 14 to 17 AWG (2.5mm² to 1.0mm²)

9.3 Outputs

- Relays: Volt-free contacts rated 2A at 30 VDC
 - Alarm: Normally open
 - Auxiliary: Normally open
 - Fault²: Closed when energized
- 0-20mA (stepped) current output: 3 wire and 4 wire configurations (sink and source).

The 0-20 mA output at different detectors status are define at the below table.

The max load of 0-20 is max 500 ohm at 18-32 VDC. The 0-20 mA is sink isolated and can be configured as source.

Detector status	Output
Fault	0 mA or 1mA ±10%
BIT Fault	2 mA ±10%
Dirty window warning	3 mA ±10%
Normal	4 mA ±10%
Pre-Alarm	16mA ±3%
Alarm	20 mA ±3%

- Tri-colour LED indication
- Modbus RTU compatible Protocol on RS-485
- HART 7

9.4 Mechanical Specifications

- Size: 5.51 x 3.54x 3.54" (140x90x90mm)
- Weight:
 - Detector (Stainless Steel 316): 6.6 lbs. (3 kg)
 - Tilt mount (Stainless steel 316): 3.3 lbs. (1.5 kg)

9.5 Environmental Specifications

- Temperature Range:
 - Operating and storage -67°F to + 185°F (-55°C to +85°C)
- Humidity: up to 99%, non-condensing
- Ingress Protection: IP66 & IP 68 (2m, 24hr); NEMA 4X & 6P

² The FAULT relay will normally be energized and the contact will be closed during normal operation of the detector. The contact will be open at fault condition or low voltage.

9.6 Product Labeling

9.6.1 Ex db

P/N <input style="width: 80%;" type="text"/>	S/N <input style="width: 80%;" type="text"/>	Mfg. Date <input style="width: 80%;" type="text"/>
<div style="border: 1px solid black; padding: 2px; display: inline-block;">ICQC 19 ATEX 0424 X</div>		<div style="border: 1px solid black; padding: 2px; display: inline-block;">CE 2549</div>
Ex db IIC T5 Gb Ex tb IIIC T95°C Db -55°C<Ta<75°C Ex db IIC T4 Gb Ex tb IIIC T105°C Db -55°C<Ta<85°C IP66 & 68 (2m, 24hr)		
<div style="border: 1px solid black; padding: 2px; display: inline-block;">FM19CA0035X</div>	Class I, Div. 1, Groups B, C & D; T4 Class I, Zone 1, AEx/Ex db IIC T4 Gb T4 -50°C≤Ta≤85°C T5 -50°C≤Ta≤75°C	
<div style="border: 1px solid black; padding: 2px; display: inline-block;">IECEx FMG19.0015X</div>	Ex db IIC T4 Gb T4 -50°C≤Ta≤85°C T5 -50°C≤Ta≤75°C	
Type 4X/6P Vin: 18-32 VDC I _{max} : 180mA Standby: 120mA		
Fire & Gas Detection Technologies 4222 E. La Palma Ave. Anaheim, CA USA		

Warning / Attention

Read and understand instruction manual before operating. Do not open when an explosive atmosphere is present. Seal All Conduits within 18 inches. Do not open when energized.

Lire et comprendre le manuel d instruction avant l' utilisation. Ne pas ouvrir quand une atmosphère explosive est présente. Sceller tous les conduits pour les 18 pouces. De pas ouvrir lorsqu'il est sous tension.

9.6.2 Ex db eb

P/N <input style="width: 80%;" type="text"/>	S/N <input style="width: 80%;" type="text"/>	Mfg. Date <input style="width: 80%;" type="text"/>
ICQC 19 ATEX 0424 X	Ex II 2 G D	CE 2549
Ex db eb IIC T5 Gb Ex tb IIIC T95°C Db -55°C<Ta<75°C Ex db eb IIC T4 Gb Ex tb IIIC T105°C Db -55°C<Ta<85°C IP66 & 68 (2m, 24hr)		
FM19CA0035X	Class I, Div. 1, Groups B, C & D; T4 Class I, Zone 1, AEx/Ex db IIC T4 Gb T4 -50°C≤Ta≤85°C T5 -50°C≤Ta≤75°C	
	Ex db IIC Gb T4 -50°C<Ta<85°C T5 -50°C<Ta<75°C	
IECEX FMG19.0015X	Type 4X/6P Vin: 18-32 VDC I _{max} : 180mA Standby: 120mA Fire & Gas Detection Technologies 4222 E. La Palma Ave. Anaheim, CA USA	

⚠ Warning / Attention

Read and understand instruction manual before operating. Do not open when an explosive atmosphere is present. Seal All Conduits within 18 inches. Do not open when energized.

Lire et comprendre le manuel d instruction avant l' utilisation. Ne pas ouvrir quand une atmosphère explosive est présente. Sceller tous les conduits pour les 18 pouces. De pas ouvrir lorsqu'il est sous tension.

9.7 Approvals

Note: All items are designed and tested to meet the relevant requirements.

- Explosion proof:
 - ATEX: II 2 G D
Ex db IIC T5 Gb or Ex db eb IIC T5 Gb and Ex tb IIIC T95°C Db -55°C<Ta<75°C
Ex db IIC T4 Gb or Ex db eb IIC T4 Gb and Ex tb IIIC T105°C Db -55°C<Ta<85°C
 - IECEx, PESO, Inmetro:
Ex db IIC T5 Gb -50°C≤Ta≤75°C
Ex db IIC T4 Gb -50°C≤Ta≤85°C
 - FM & FMC:
Class I, Div. 1, Groups B, C & D; T4
Class I, Zone 1, AEx/Ex db IIC T4 Gb
T4 -50°C≤Ta≤85°C
T5 -50°C≤Ta≤75°C
- Performance:
 - ANSI FM 3260
- Functional safety: Meets the requirements for SIL 2 per IEC 61508.
- California Fire Marshall
- EAC CU TR

9.8 Electromagnetic Compatibility

The detector fully complies with EMC directive 2014/30/EU and protected against interference caused by RFI and EMI. The cables to the detector must be shielded and the detector must be grounded in order to comply to the EMC directive.

10 Performance

The following tables show test results of detection distances and times for different fire scenarios. Each table lists results for a different sensitivity setting. For liquid fires the size of fire refers to the size of the pan, filled with the fuel. For gas fires the length of the plume is listed.

10.1 FLS-IR3-H2-ASX1 (Standard Model)

Extreme Sensitivity

Fuel	Pan Size	Distance ft (m)	Average Response Time (Seconds)
Methanol	1 x 1 ft	59 (18)	4.2
H ₂	32-in Plume	98 (30)	1.5
Methane	32-in Plume	66 (20)	1.7
Syngas	32-in Plume	82 (25)	3.0

Medium Sensitivity

Fuel	Pan Size	Distance ft (m)	Average Response Time (Seconds)
Methanol	1 x 1 ft	30 (9)	2.9
H ₂	32-in Plume	66 (20)	1.5
Methane	32-in Plume	66 (20)	1.2
Syngas	32-in Plume	82 (25)	3.0

Low Sensitivity

Fuel	Pan Size	Distance ft (m)	Average Response Time (Seconds)
H ₂	32-in Plume	66 (20)	1.4
Methane	32-in Plume	66 (20)	1.4
Syngas	32-in Plume	82 (25)	0.8

Very Low Sensitivity

Fuel	Pan Size	Distance ft (m)	Average Response Time (Seconds)
Methanol	1 x 1 ft	10 (3)	4.9
H ₂	32-in Plume	16 (5)	1.5
Methane	32-in Plume	13 (4)	0.9
Syngas	32-in Plume	13 (4)	2.1

*Syngas mixture: 50% volume methane, 50% volume hydrogen

For performance details of model 5 the following documents are available, on request:

Model 5 - fast response enclosed space / automotive / spray paint booth applications F101V0023.06

10.2 False Alarm Immunity

The following table shows test results of false alarm immunity for detectors configured to “Extreme” sensitivity. For each radiation source a distance is listed. This is the minimum tested distance, from which the detectors did not alarm when exposed to the radiation source (either modulated or non-modulated).

False Stimuli only at Extreme Sensitivity

False Alarm Source	Maximum Distance in ft (m)
Sunlight, Direct, Reflected	No response at any distance
Sunlight, Direct, reflected with water drops on sensors	No response at any distance
Incandescent frosted glass light, 300W	2 (0.5)
Fluorescent, 70W (3x23.3W)	2 (0.5)
Electric arc	3 (1)
Arc welding	2 (0.5)
Radiation heater, 1850W	2 (0.5)
Radiation heater, 1850W with water drops on sensors	2 (0.5)
Quartz lamp (1000W) shielded	2 (0.5)
Quartz lamp (500W) non-shielded	2 (0.5)
Quartz lamp (500W) non-shielded with water drops on sensors	2 (0.5)
Mercury vapor lamp 160Wx3	2 (0.5)
Car Exhausts	2 (0.5)
Projector led	2 (0.5)
Solenoid bell	2 (0.5)
Soldering iron	2 (0.5)
Electric Drill	2 (0.5)

11 Ordering Information

Part Number	Description
Flame Detector	
FLS-IR3-H2-AS11	FlameSpec IR3-H2, ATEX, FMus, FMc and IECEx Certified, SS316, M25 Entries
FLS-IR3-H2-AS21	FlameSpec IR3-H2, ATEX, FMus, FMc and IECEx Certified, SS316, 3/4"NPT Entries
FLS-IR3-H2-AS15	As FLS-IR3-AS11 but with enhanced speed of response option – NFPA33
FLS-IR3-H2-AS25	As FLS-IR3-AS21 but with enhanced speed of response option – NFPA33
Detector Tilt Mount	
FLS-TMO-S01	FlameSpec Stainless Steel Tilt Mount
Flame Simulator Kit	
FLS-FSIM-IR3-H2-KIT	IR3 H2 FlameSpec Flame Simulator Kit Including Carry Case, Simulator, Carrying Strap, Charger and Manual
Flame Simulator Spare Parts	
FLS-FSIM-CASE	Carrying Case
FLS-FSIM-STRAP	Carrying Strap
FLS-FSIM-TOOL	Cover Removal Tool
FLS-FSIM-ALLEN	Allen Key
FLS-FSIM-CHRGR	Power Supply and Charger
FLS-FSIM-BATT	Replacement Battery
Flame Detector Accessories	
FLS-WCO-S01	Weather Cover, SS316
FLS-PMA-S23	Pole Mounting Adaptor, SS316, 2 Inch and 3"inch
FLS-ADS-S01	Air Shield
Communications	
USB/RS485	RS485 to USB Converter (for connection of detector RS485 output to PC/Laptop for use with FGD Communicator Software)

12 Warranty

FIRE & GAS DETECTION TECHNOLOGIES INC. agrees to extend to Purchaser/Distributor a warranty on the FIRE & GAS DETECTION TECHNOLOGIES INC. supplied components of the FlameSpec products. FIRE & GAS DETECTION TECHNOLOGIES INC. warrants to Purchaser/Distributor that the products are free from defects in materials and workmanship for a period of five (5) years, commencing with the date of delivery to Purchaser/Distributor. FIRE & GAS DETECTION TECHNOLOGIES INC. expressly excludes damage incurred in transit from the factory or other damage due to abuse, misuse, improper installation, lack of maintenance or "Act of God" which are above and beyond its control. FIRE & GAS DETECTION TECHNOLOGIES INC. will, upon receipt of any defective product, transportation prepaid, repair or replace it at its sole discretion if found to have been defective when shipped. Said repair or replacement is FIRE & GAS DETECTION TECHNOLOGIES INC. sole liability under this warranty and FIRE & GAS DETECTION TECHNOLOGIES INC. liability shall be limited to repair or replacement of the component found defective and shall not include any liability for consequential or other damages. The customer is responsible for all freight charges and taxes due on shipments both ways. This warranty is exclusive of all other warranties express or implied.

Appendix A

HART 7 Communications

HART (macronematous of Highway Addressable Remote Transducer) establishes digital data communication over 4-20mA Current Loop cables. The HART protocol uses FSK modulation signals superimpose at low level on top of the 4-20mA current.

The HART implementation on the FlameSpec IR3/IR3-H2/UV-IR Flame Detector allows the Control Unit to monitor the status of the detector, settings of User Configuration and initiate field diagnostics.

The HART protocol implemented in this flame detector is corresponds to HART rev. 7.0. It supports HART Universal commands including Common Practice and Device Specific Commands. For more detail information see manual F110V0050

Contact us

Fire & Gas Detection Technologies, Inc

4222 E. La Palma Ave, Anaheim, CA 92807, USA

Tel: (+1) 714 671 8500

Email: support@fg-detection.com

