

Honeywell

Honeywell Model 700/800 Signal Processor and Viewing Head

TECHNICAL CATALOG



- Model 700ACSP Universal 85-265 VAC powered, plus 24VDC backup.
- Model 700DCSP 22-26VDC powered, plus 24VDC backup.

The two Model 700 signal processors are similar, with 12 push-buttons, a two-digit numeric display, and four LED status indicators for operator interface. The only difference between the two is that one accepts AC power and the other accepts DC power. Both models also accept 24VDC backup power. Most of the signal processor connections are made through Phoenix plug-in connectors. Communication connections are made through modular phone jacks located at the top of the signal processors (Fig. 9).

Both signal processor models mount on a standard 35 mm DIN rail. They snap into place and may be released from the rail using a flat screwdriver.

There are two types of viewing heads—IR/flicker-sensitive and UV-sensitive—with various features offered resulting in ten different models. See Table 1 on page 2 for details.

The S702 and S706 viewing head housings are larger in diameter than the S80X series, are made of aluminum, and are secured with over-center latches to their mounting blocks (Fig. 10). In contrast, the S802 and S806 viewing head housings are smaller in diameter and are made of stainless steel (Fig. 11). An 800 series viewing head is secured in its mounting block by a friction twist-lock.

The IR/flicker sensitive viewing heads have a high-pass filter that passes flicker frequencies above 33 Hz. The UV models respond to the level of UV radiation—not UV flicker—so there is no filter option.

APPLICATION

The Honeywell Model 700ACSP and Model 700DCSP signal processors are single-channel, fail safe, flame monitoring systems when used in conjunction with the S70X/S80X viewing heads. They offer easy setup, excellent discrimination, and high reliability.

FEATURES

Viewing heads are interchangeable between the two signal processor models. Any viewing head in the two families will work with any of the signal processors.

Two signal processor models are available:

Contents

Application	1
Features	1
Specifications	2
Approvals	3
Installation	3
Operation	11
Modbus Communication	17
Troubleshooting	20
Maintenance	20
Safety Manual: 700 Signal Processor	36
Safety Manual: S70X & S80X Viewing Head	39



Table 1. Available viewing head models and associated features.

Model	Connector	Pipe Fit Connection 0.5 in. NPTM with 10- ft (3 m) pigtail	UVTron Sensor	IR Sensor	High Frequency Filter 155Hz	Aluminum Housing	Stainless Steel Housing
S702	X			X		X	
S702PF		X		X		X	
S706	X		X			X	
S706PF		X	X			X	
S802	X			X			X
S806	X		X				X

1. All models include Electronic self-check.
2. Flicker Frequency filter settings available for IR sensor models.
3. Gain Selection available through Signal Processor.

The viewing heads, the viewing head connector, and the 15 foot cable provided are watertight, and have IP64 ratings when the connector is properly tightened with pliers and the cable is protected from UV exposure.

The availability of both UV-sensing and IR/flicker-sensing viewing heads ensures that the flame monitoring systems can provide good discrimination in most single and some multiple burners firing a single fuel. UV sensing is appropriate for monitoring natural gas, some mixed gases and light oil flames. IR/ flicker sensing is appropriate for monitoring heavy oil and coal flames.

SPECIFICATIONS

Series 700 and 800 Viewing Heads

MODELS S702, S702PF, S706, AND S706PF MODELS S802 AND S806

Electrical

24VDC Power is supplied by Signal Processor

Environmental

Viewing Head Sealing: IP64 rated when the metallic connector ring is tightened with pliers and a UV protection is provided for the cable by installing in conduit.

Ambient Temperature: -40°F to 185°F (-40°C to 85°C)
CSA for CLASS I, DIV 2, GROUPS A, B, C, D, T4A
-40°F to 149°F (-40°C to 65°C) IECEx CSA Ex nA IIC T4 Gc

IR Detector Spec

S702, S702PF, S802: Germanium photodiode with spectral response 950nm to 1710nm (1/2 intensity points) and peak spectral response at 1400nm
High Pass Filter Pickup: 33 Hz standard

IR Optical

Angle of View: 1 degree (1.45 in. dia. at 6 ft. or 3.7 cm dia. at 1.8 m)

UV Detector Spec

S706 & S706PF, S806: UVtron with spectral response 185nm to 260nm and a peak response at 210nm

UV Optical

Angle of View: 5 degrees (1 inch per foot)

Cable & Connectors - S70X/S80X Viewing Heads

New installations - highest level of EMI shielding available:

- ASY785 --> 50 foot C330S cable with pre-wired ASY786 connector.
- ASY785-200 --> 200 foot C330S cable with pre-wired ASY786 connector.
- ASY786 --> Field wireable connector with shield.

Dimensions

Refer to Fig. 10 and Fig. 11.

Model 700ACSP & Model 700DCSP Signal Processor

Electrical: Model 700ACSP

Primary Input Power: 85-265VAC, 50-60 HZ, 0.07A Max. fused (with either V.H. connected)
Battery Backup Voltage: 22VDC to 26VDC, 0.2A DC Max. fused (with either V.H. connected)

Electrical: Model 700DCSP

Primary Input Power: 22VDC to 26VDC, 250 mA Max. fused (with either V.H. connected)
Battery Backup Voltage: 22VDC to 26VDC, 0.5A DC Max., fused (with either V.H. connected)

Outputs

Flame Relay: 2 form C contacts
Self-Checking Relay: 1 form C contact
Relay Contact Ratings: 5A at 125 VAC, 277 VAC, & 30 VDC; 1/8 HP 125 & 250 VAC
Analog Flame Signal: Isolated 0 to 20 mA or 4 to 20 mA output for remote meters or DCS, 360 ohms maximum resistance

Environmental

Ambient Temperature: 32°F to 140°F (0°C to 60°C)

Dimensions

Refer to Fig. 12 and Fig. 13.

APPROVALS

S70X/S80X Viewing Heads (Connector series and Pipe fit series [PF])

CSA for CLASS I, DIV 2, GROUPS A, B, C, D & T4A
SIL 3 "Fit for Use" $-40 < T_a < 85^{\circ}\text{C}$, $-40 < T_a < 185^{\circ}\text{F}$

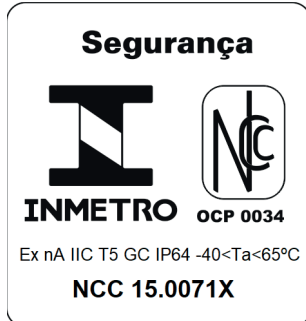

IECEX CSA Ex nA IIC T5 GC IP64
 $-40 < T_a < 65^{\circ}\text{C}$, $-40 < T_a < 149^{\circ}\text{F}$

*IP64 rating applies when connector ring is properly tightened and cable is UV shielded

Special Conditions for Safe Use: The input voltage rating of the equipment (22 to 26 VDC) must be protected so that the transients are limited to a surge of 119 V. This protection is not necessary for the signal output lines.

KTL
S702/S706 Viewing Head (Connector series)



KTL
15-KA4BO-0199X

KTL
S702PF/S706PF Viewing Head (Pipe fit series)



KTL
15-KA4BO-0196X

KTL
S802/S806 Viewing Head (Connector series)



KTL
15-KA4BO-0197X

700ACSP and 700DCSP Signal Processors

CSA (C, US)
FM

INSTALLATION

When Installing These Products...

1. Read these instructions carefully. Failure to follow them could damage the products or cause a hazardous condition.
2. Check the ratings given in the instructions and one the products to make sure the products are suitable for your application.
3. Installer must be a trained, experienced, flame safeguard control technician.
4. After installation is complete, check out product operation as provided in these instructions.

Signal Processor Mounting

The 700ACSP and 700DCSP signal processors mount on a standard 35mm DIN rail. They snap into place and may be released from the rail using a flat screwdriver.

Grounding and Shielding

NOTE: Installer must be a trained, experienced flame safeguard service technician and should be familiar with the equipment operation and limitations and be aware of any applicable local codes and regulations.

1. Connect a safety ground to the viewing head housing (if applicable). A ground screw is provided on the exterior of s70x/s80x viewing head housings for this purpose.

⚠ WARNING

The viewing head housing is grounded through cable/signal processor, so you must ensure that AC/DC potentials at ground of signal processor and viewing head are the same, or damage to the cable or signal processor can result.

2. The viewing head and all associated cable/conduit must be at least 12 inches (31 cm) from any source of high energy or voltage (for example, igniter equipment).
3. Install a ground wire from the ignition transformer case to the igniter assembly.
4. Ensure all igniter wires and cables show no signs of wear. Replace any igniter cables or wires that are frayed or cracked.
5. The viewing head must be electrically isolated from the burner front.
 - a. Electrical isolation can be accomplished by installing an Ultem nipple (R-518-13) or an Ultem locking coupler adapter (R-518-PT13 or R-518-PT13L) in conjunction with a locking coupler (R-518-CL13-HTG) between the viewing head flange and the burner mount.

- b. The purge air line should also be isolated from the viewing head. This can be accomplished by installing any insulating material, for example a rubber hose, in between the purge air line and the viewing head.

Signal Processor Power Connections

The Model 700ACSP power and relay connections are shown in Fig. 1. The AC power supply to the 700ACSP Signal Processor passes through a 2A fuse and an inrush current limiter.

The Model 700DCSP power and relay connections are shown in Fig. 2. The maximum current requirement for each 700DCSP is 250mA.

In the Model 700 signal processors the flame relay (RF A/B ON, OFF, COM) has two sets of FORM C (SPDT) contacts and the self-check relay (SC ON, OFF, COM) has one set (Fig. 1 and Fig. 2). The self-check relay is energized whenever the signal processor is powered and is operating normally, whether the flame relay is energized or not. Internally, the flame relay is wired in series with the self-check relay (not shown), which prevents the flame relay from energizing if the self-check relay is not energized.

Unique fail-safe circuitry for the self-check and flame relays ensure that in the event of any critical component failure occurrence, system response will be to de-energize the self-check relay, which in turn de-energizes the flame relay.

Some of the internal power wiring of the Model 700ACSP and Model 700DCSP signal processors is shown in Fig. 1 and

Fig. 2. Rectifier diodes separate the battery backup input from the main power bus until the battery voltage exceeds the internal DC voltage plus a diode voltage drop.

Resettable fuses (shown as resistors with slashes) and conventional fuses prevent internal failures from loading the power sources.

With the Model 700DCSP, if a backup battery is to be used with a main power supply, the two power sources would be wired as shown in Fig. 2. If no backup battery is to be installed, the main power supply can be connected at +26V PWR and GND as shown in Fig. 2 or it can be connected to the +24V BATT input and GND. It is preferable to use the battery connections because it takes advantage of the resettable fuse at the battery input; resettable fuses recover automatically from a fault within a few seconds after power is removed. At the +26V PWR input and its associated GND, conventional 1A fuses are used because they are able to protect against 240VAC being applied by accident (this could happen if a Model 700DCSP is installed in a cabinet wired for a Model 700ACSP).

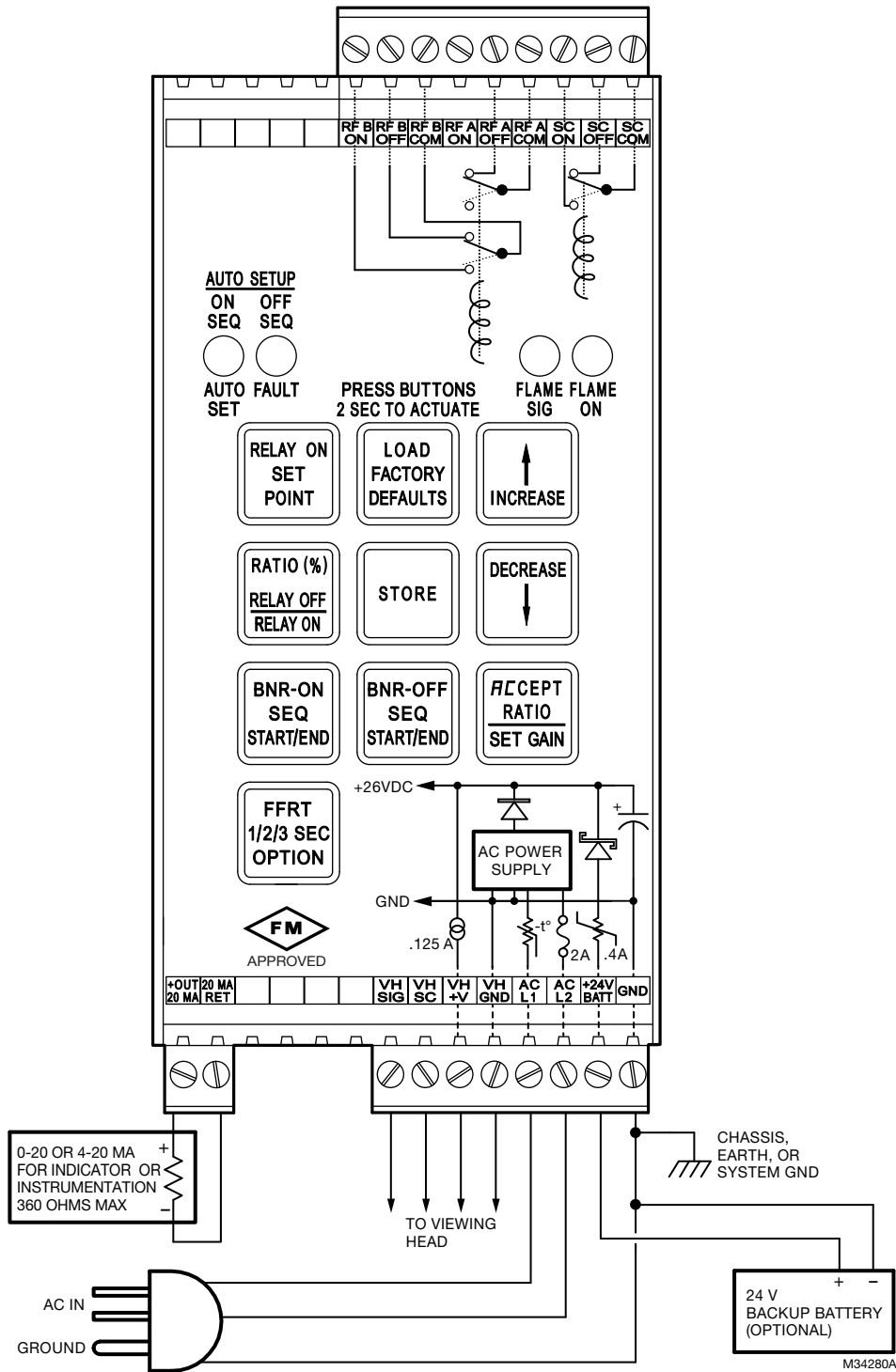

Fig. 1. Model 700ACSP Signal Processor Wiring.

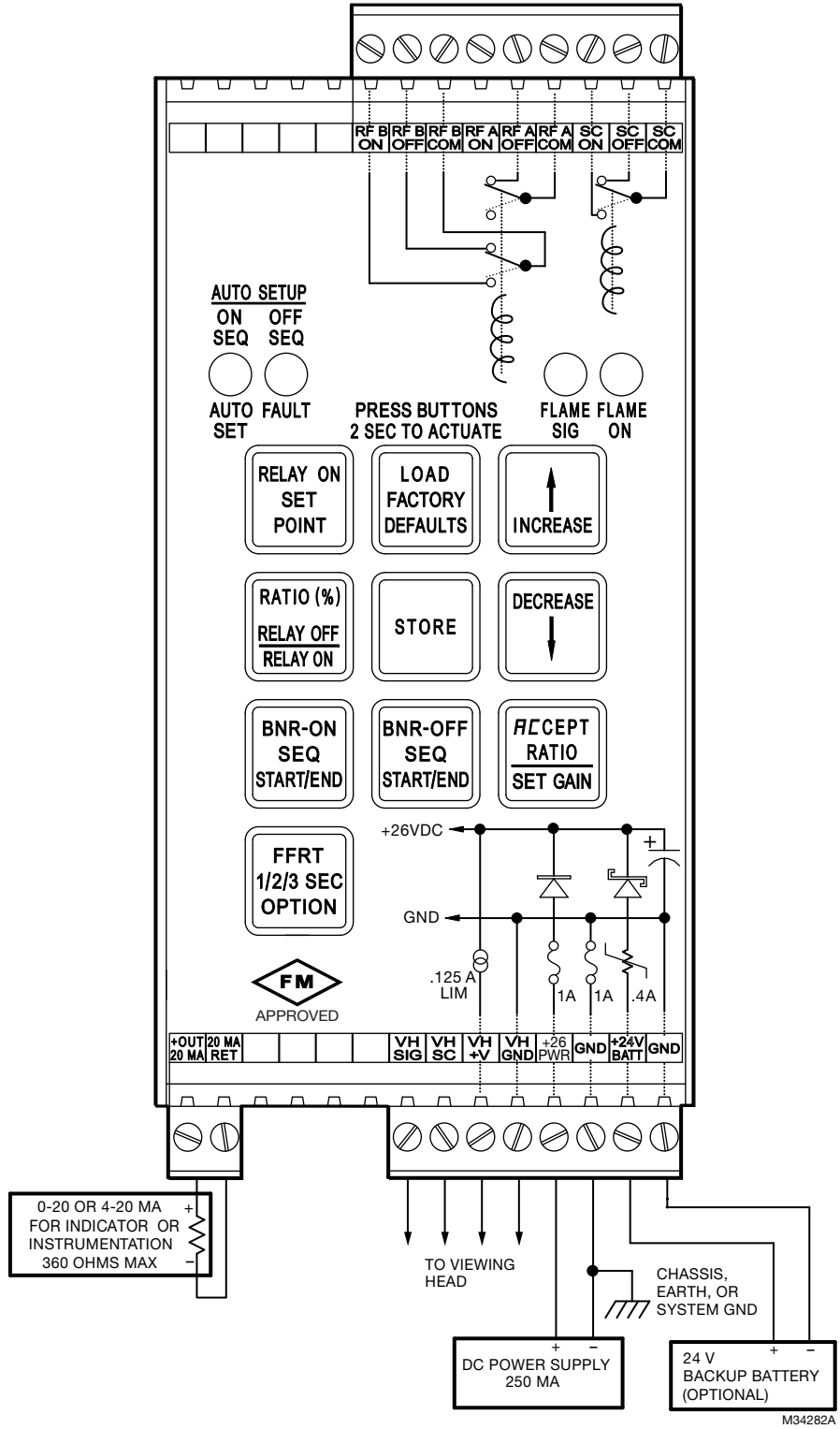

Fig. 2. Model 700DCSP Signal Processor Wiring.

Viewing Head Connector and Wiring

Viewing heads are wired to the appropriate terminals located on bottom of the 700ACSP, 700DCSP, P531 or P532 signal processors. The terminals are listed functionally in Table 2.

Table 2. Terminal Descriptions.

700ACSP or 700DCSP Terminal	P531 or P532 Terminal	Description
VH SIG	VH3 SIG	Flame Signal from Viewing Head
VH SC	VH3 SC	Shutter Drive Signal to Viewing Head
VH +V	VH3 +V	+24VDC Power to Viewing Head
VH GND	VH3 GND	GND Signal Ground

Connectors and cables are shown in Fig. 3, Fig. 4, and Fig. 5. Fig. 3 shows the viewing head cable with the 1/2 in. NPT pipe fitting and pigtail for use in a conduit. The PF model comes with 10 feet of Honeywell C330S cable. This cable is recommended for all new installations. It has ITC and CIC ratings for hazardous location. Figs. 4 and 5 describe the C330S cable used with the right angle field-wireable connector. Refer to “Accessories” on page 11 for part numbers.

S70x/S80x Viewing Head Hazardous Location Installation of Cables and Connectors



WARNING

EXPLOSION HAZARD

DO NOT CONNECT OR DISCONNECT THIS EQUIPMENT UNLESS POWER HAS BEEN REMOVED OR THE AREA IS KNOWN TO BE NONHAZARDOUS.

SUBSTITUTION OF COMPONENTS MAY IMPAIR SUITABILITY FOR CLASS I, DIVISION 2.



AVERTISSEMENT

RISQUE D'EXPLOSION

NE PAS DEBRANCHER TANT QUE LE CIRCUIT EST SOUS TENSION, A MOINS QU'IL NE S'AGISSE D'UN EMPLACEMENT NON DANGEREUX.

LA SUBSTITUTION DE COMPOSANTS PEUT RENDRE CE MATÉRIEL INACCEPTABLE POUR LES EMPLACEMENTS DE CLASSE I, DIVISION 2.

The S70x/S80x viewing heads must be installed with a connector and cable assembly that maintains the ingress protection at the S70x/S80x viewing head. Additionally, ITC/CIC approved cable installed in cable tray, or ITC/CIC approved cable in metal conduit must be used between the S70x/S80x and Signal Processor. Pre-assembled connector/cable assemblies are listed below that provide the proper seal at the viewing head, and meet ITC/CIC approvals. A field wire-able connector that provides a proper seal at the viewing head, along with ITC/CIC rated raw cable are also available and listed below. The cable installation must conform to the latest version of the National Electric Code, or Canadian Electrical Code for Class I, Division 2 hazardous locations.

Additionally, the connector must be secured as follows: hand-tighten the connector at viewing head, until it can no longer be turned. Continue tightening the connector an additional 180 degrees using pliers, or similar tool.



WARNING

Over-tightening the connector can damage the connector or housing.

Damage will void warranty and hazardous location approvals. Do not exceed 180 degrees of further rotation after hand tightening!

Verify that connector cannot be loosened by hand. This is required for hazardous location installations.

ASY785 – Pre-assembled connector with led indicators and 50 foot cable assembly, IP67 rated with CIC/ITC approved cable.

ASY785-200 – Pre-assembled connector with led indicators and 200 foot cable assembly, IP67 rated with CIC/ITC approved cable.

C330S – ITC/CIC rated 4 conductor 22g cable with drain wire, and overall shield.

ASY786 – Field wireable connector with led indicators , IP67 rated.

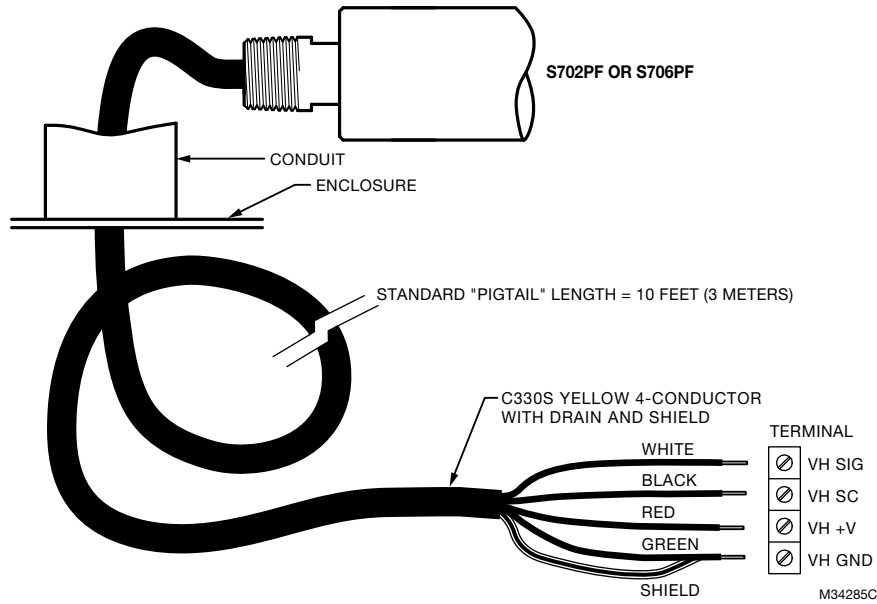

Fig. 3. Model 700 Viewing Head Cable With 1/2 in. NPT Fitting.

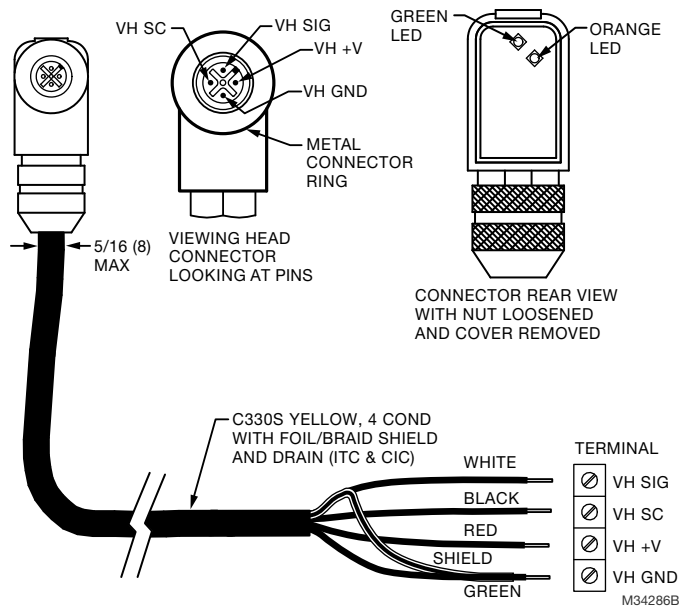

Fig. 4. Model 700/800 Viewing Head Cable Connections.

Cable Preparation

NOTE: This section will typically be used for reference only. The S70X/S80X connector parts are very small and delicate and difficult to assemble. It is advisable to purchase pre-made cables from Honeywell.

Honeywell C330S cable is recommended for use with the S70X/S80X viewing heads and signal processors. C330S has a UL ITC rating and can be used in the U.S. in hazardous locations.

NOTE: Shield shrink tubing is required on shield drain wire at the signal processor end.

Preparation of the C330S cable at the signal processor should be done as follows:

1. Referring to Fig. 5, strip cable 2 inches back to expose the braided shield.
2. Pull braided and foil shield back so that only drain wire is at 2 inch length. Trim the foil and braid shields at the cable jacket.
3. Insulate the drain wire with heat shrink.
4. Strip other wires as shown in Fig. 5.

Connection of the Honeywell type C330S cable to the viewing head plug is shown in Fig. 7. Cable preparation should be done as follows:

1. Prepare C330S wire at plug end similarly to Fig. 5.
2. Assemble the field-wireable plug as shown in Fig. 7. Ensure that:
 - a. Wires and LEDs are in proper locations per Fig. 4.

- b. Braided shield is on outside of ferrule, and pressed against housing when assembled.
- c. Solder drain wire to housing at one of two holes at entry (see Fig. 6).
- d. Connector back plate gasket is in place before installation.
- e. After assembly, check that connector is tight and well secured.

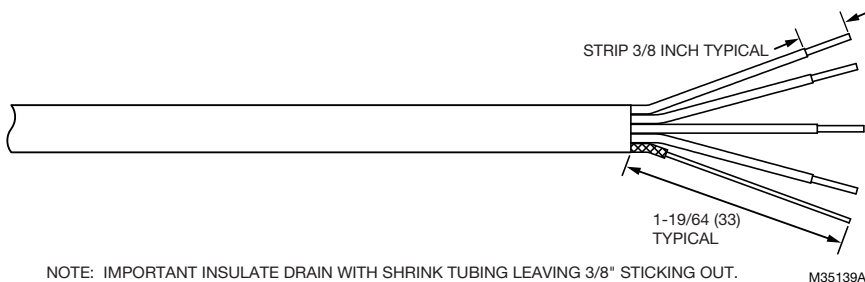

Fig. 5. C330S Signal Processor End Cable Preparation.

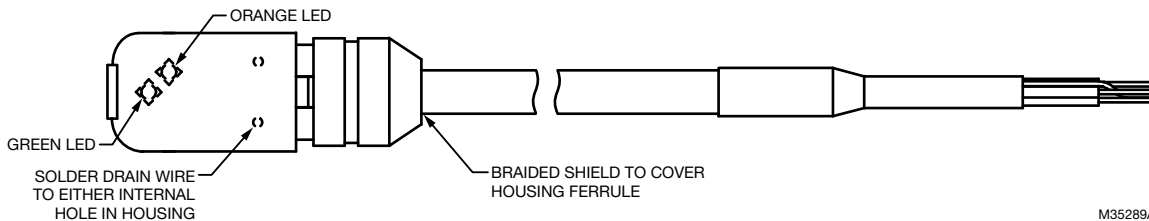

Fig. 6. Soldered Drain Wire Location.

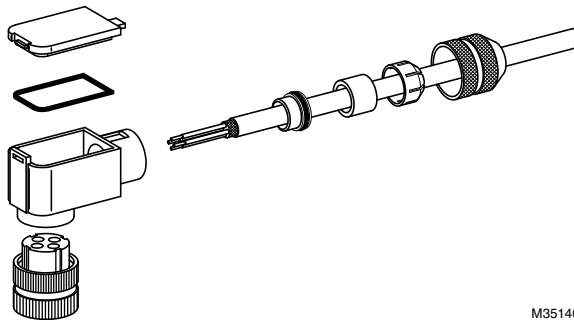

Fig. 7. ASY786 Viewing Head Plug Assembly with C330S.

Protecting the Viewing Head Cable (Connector Series)

Note that when the wiring needs to meet Class I, Division 2 requirements for use in hazardous locations and when conduit is used, the conduit must be sealed where the cable passes from the hazardous location to the non-hazardous location in order to keep potentially hazardous gases from being conducted into the non-hazardous area.

Viewing Head Connector LED Indicators

The viewing head connector has orange and green LEDs which can be viewed from the rear of the connector when the connector cover is removed.

The green LED displays the pulses out of the viewing head and the orange LED shows that the self-checking signal from the signal processor is reaching the viewing head. If power is on at the signal processor, the orange LED should flash at one pulse per second, even if the viewing head is not plugged in. This is helpful in troubleshooting.

With no flame signal present, the green LED will flash one pulse per second in step with the self-checking signal. The viewing head is sending back an ID pulse; this is part of the self-checking system. When a flame is present, the green LED will flash at a rate proportional to the flame signal, except when the pulses are interrupted once per second for the self-check pulse arrival at the viewing head. The pulse rate of the green LED flashes can be used for aiming the viewing head.

NOTE: The LED indicators are provided for alignment and troubleshooting only. Reinstall cover with gasket correctly in place at all times, and ensure that connector coupling is tightened securely. This gasket and cover must be installed properly to maintain IP67 rating.

Viewing Head Mounting and Sighting

Mounting is 1/2-in. NPT (F) for all viewing head models with a 1/4-in. NPT (F) purge air connection. Before beginning installation, determine the best location for mounting the viewing head based upon the following factors:

Viewing Head Mounting Block

The S70X viewing heads are held firmly in place in their mounting blocks by two zinc-plated steel latches. The S80X viewing head is secured in its mounting block by a friction twist-lock. Refer to the ACCESSORIES section for part numbers.

Pressure

The S70X viewing head lens will withstand 50 psi (3.4 bar) while the S80X lens will withstand 90 psi (6.2 bar), provided the compression ring on the purge air adapter is tightened properly. If the lens assembly is exposed to greater pressures through the sight pipe, then an isolation unit must be used. Honeywell isolation units with purge air entrance are available as accessories; ISO-UNIT, ISO-UNITSS, ISO-UNITHPGT. Each has a quartz window, two 1-in. NPTF connections and a 1/2-in. NPTF purge port.

Temperature

The case temperature of the viewing head housing must not exceed 185°F (85°C) while the standard Delrin mounting block must not exceed 180°F (82°C) continuous service. Care should be taken to ensure the case housing and mounting block temperatures do not exceed these values.

Purge air will help reduce conducted heat through the sight pipe and flange. A heat insulating Ultem replacement viewing head mounting block is available for both the S70X/S80X models (part numbers 700UA and 800UA) with a continuous service rating of 320°F (160°C) as well as a 1/2-in. NPTM Ultem nipple (part number R-518-13) or an Ultem locking coupler adapter (R-518-PT13 or R-518-PT13L) to reduce the conducted heat, but direct radiation can cause the housing case temperature to exceed limits. If the ambient heat (direct radiation) is excessive, then an air cooling canister with vortex cooler should be considered or alternately a fiber optic extension. The extension uses a fiber optic cable assembly between

the sight pipe and the viewing head, allowing the viewing head to be placed further away from the heat source. Refer to the Fiber Optic Manual 69-2683 or contact your distributor or the factory for assistance with fiber optic selection and pricing.

Purge Air

Use a flexible air supply line, to allow for repositioning of the viewing head and sight pipe until a final and permanent position has been decided. A continuous flow of air must be maintained in order to reduce the conducted heat and to keep the sight pipe and viewing head lens free of dirt and debris. Air required is about 5 SCFM (0.13 Nm³/min) delivered at 1 in. (25mm) above the maximum pressure as measured at the “Y” or “T” section of the purge air connection for each viewing head. The air supply must be clean, free of oils and water, and preferably cool. In order to electrically isolate the viewing head, the purge air line should be installed using an insulating material, such as a rubber hose, in between the purge air line and the viewing head.

Vibration

Do not install the viewing head where it could be subject to high vibration. Provide an anti-vibration mount if excessive vibrations are present.

Clearance

Make sure there will be sufficient room to remove the viewing head housing for servicing.

Viewing Head Mounting

Honeywell offers a range of swivel mounts, both pipe thread or flange mounting for use with sight pipes or direct wind box mounting. See “Accessories” on page 11. or the Honeywell website for further details.

Viewing Head Sighting

The sighting of the viewing head should be parallel to the center line of the burner in the direction of the flame. If used, the sight pipe should be mounted as close to the center line as possible so as to sight along the flame rather than across the flame. Doing so will ensure continuous flame detection under changing load conditions. See Fig. 16, 17 and 18.

Utilizing a sighting or the sight pipe aimed at the root of the flame (where the turbulent combustion air mixes with the flame) is a good starting point for optimizing the sighting. Where practical, using a swivel mount to “zero-in” on the highest signal will assure maximum performance. The optimum scanner location is parallel to the burner center line. The use of a swivel mount allows for line of sight adjustment, where practical to use.

Examples of viewing head installation with and without a swivel mount are shown in Fig. 14 and Fig. 15. If using a sight pipe, its diameter should be large enough to allow a reasonable field of view, and to allow for adjustment of the swivel mount angle.

In some instances, it may be beneficial to use two sets of setpoints for Flame On, Flame Off and gain. The two-channel capability (primary and alternate viewing head settings) is ONLY possible when using the P531 or P532

signal processors; it is not possible when using the 700ACSP or 700DCSP signal processors. The switch-over from Channel A to Channel B can be implemented from the burner control system. Refer to the P531/P532 user manual, 66-2068, for further information regarding switch-over and the use of Channels A and B with independent settings.

ACCESSORIES

Orifice disks (kit M-702-6) - Used to reduce the signal brightness in cases where the signal brightness is too strong. Located immediately in front of the lens, it will reduce the amount of signal to the sensor. Bag assembly contains orifice disks and retaining rings. Orifice disks come with 3/8, 1/4, 3/16 and 1/8 inch diameter holes. Contact the factory for guidance in using orifice disks.

Insulating nipple (R-518-13) - 1/2-in. NPTM Ultem heat and electrical insulating nipple typically used in conjunction with a swivel mount and union.

VH insulating mounting block (700UA, 800UA) - 1/2 in. NPTF Ultem heat and electrical insulating mounting block, used in place of the supplied Delrin mounting block. 1/4 in. NPTF purge air connection. Typically used in conjunction with a swivel mount. Rated for continuous service up to 320°F (160°C).

Swivel mounts, small (700-1, 700-2, 700-3) - All have 1/2 in. NPTM viewing head connections on one end with varying process connections including 1 in. NPTF, 1/2 in. NPTF and 1/2 in. flanged.

Swivel mounts, large (M-701-1, M-701-2, M-701-2-FLG, M-701-2-SS, M-701-3, M-701-3P, M-701-4) - All have 1 in. NPTF viewing head connections, one end with varying process connections including 2 in. pipe slip on, 2 in. NPTF, 2 in. flanged, 2 in. NPTF in stainless steel construction, 4.5 in. flanged with 3 bolts, 3 in. NPTF and 2-bolt flanged. Appropriate fittings must be used to adapt the 1/2 in. NPTF viewing head process connections.

Insulating locking coupler adapters (R-518-PT13, R-518-PT13L) - 1/2 in. NPTM Ultem adapters insulate the viewing head electrically and thermally and are used with the R-518-CL13-HTG locking couplers. The R-518-PT13L has a quartz lens.

Locking coupler (R-518-CL13-HTG) - Used with the R-518-PT13 and R-518-PT13L insulating locking coupler adapters. Process connection end is 1/2 in. NPTF.

Connector
ASY786 --> Replacement field wireable connector.

Cable and Connectors - S70X/S80X Viewing Heads
ASY785 --> 50 foot C330S cable with pre-wired ASY786 connector.
ASY785-200 --> 200 foot C330S cable with pre-wired ASY786 connector.

Cable (C330S) - 4-conductor with drain, foil/braided shield. Sold per foot.

Isolation Units (ISO-UNIT, ISO-UNITSS, ISO-UNITHPGT) - All have 1 in. NPTF connections with 1/2 in. NPTF purge ports and quartz window. Black anodized aluminum or stainless steel construction. The HPGT version has a 1/2 in. thick quartz window for higher pressures. Appropriate fittings must be used to adapt the 1/2 in. NPTF viewing head process connections.

Air cooling canister (700ACC, 800ACC) - Has an air inlet port on side. Used with vortex coolers. S80X models can be used with the 700ACC if the 800ACC-RING adapter is used.

Vortex coolers (M3204, M3208, M3210, M4025) - Used with air cooling canister. Contact your distributor or the factory for selection assistance.

Cable restraints (800CR, 700CRLT) - Liquid tight S80X and S70X cable restraint versions. The 800CR includes the 700CRLT and the 800ACC-RING adapter.

S80X adapter ring (800ACC-RING) - Adapter ring to fit S80X viewing heads to 700ACC cooling jacket and 700CRLT liquid tight cable restraint.

Mounting blocks (700DA, 700DA-1, 800DA) - Delrin replacement adapter/mounting blocks for S70X and S80X viewing heads. All have 1/4 in. NPTF purge air connections. Rated for continuous service up to 180F (82C). The 700DA and 800DA have 1/2 in. NPTF process connections while the 700DA-1 has a 1 in. NPTF process connection. For more 1 in. NPT accessories that can be used with the 700DA-1, refer to the S55XBE manual, 66-2064.

USB to RS422/RS485 Converter (COMMODO) - Protocol converter for use with external communication with a remote computer.

Fiber Optic System Compatibility - The S70X and S80X viewing heads are compatible with the Honeywell FASA fiber optic extension products. The S700FOAD and S800FOAD adapters are applicable, depending on the application. Contact your distributor or the factory for assistance with fiber optic selection and pricing.

OPERATION

IR Detector

The S702 and S802 viewing head models use a Germanium photodiode, which responds to IR radiation/flicker in the flame. Flame flicker is caused by the combustion, or forced air injected in to the flame. Combustion air can be mixed with the fuel (pulverized coal) or can be introduced separately. In either case, forced air is introduced in such a way as to aid the combustion process. This air is usually made turbulent by causing it to swirl with spin vanes located in the burner throat. Flame flicker is created when turbulent air mixes with the flame. It is composed of random frequencies and the amount of high frequency flicker is dependent on the fuel and the burner.

The S702, S702PF and S802 viewing head models respond to flicker frequencies above 33Hz. All flicker frequencies below the filters are ignored, so it is important

to sight the viewing head on the highly turbulent portion of the flame that contains the higher frequencies. The location of the higher frequencies can be predicted by examining the burner with regard to where the turbulent air enters the flame. The optimum scanner location is parallel to the burner center line (Fig. 16). The use of a swivel mount is encouraged to allow for line of sight.

IR Sensor Saturation

IR viewing head levels that exceed the range of the scanner will indicate flamecounts 29 at the 700 display. This is IR sensor saturation. Saturation may occur from large flickering IR, or extremely high non-flickering IR (high temp or high gain setting). This allows for IR discrimination in low to high IR intensity applications while preventing nuisance shutdowns. See Setup and Adjustment Procedures for more information on proper setup.

UV Detector

The S706, S706PF and S806 viewing head models use the UVTron tube, with a spectral response of 185-260nm and peak response of 210nm to ultraviolet radiation. The output of the detector is a pulse stream of randomly spaced pulses whose average rate is proportional to the UV radiation present in the flame. The UV radiation is a direct result of the combustion process as oxygen combines with hydrocarbons in the fuel in the blue part of the flame. The yellow part of flames, and the background radiation from hot refractory, do not emit UV radiation.

The spectral range of the UV tube makes it ideal for discriminating between flame and glowing refractory. As with any UV radiation, it can be absorbed or masked by unburned fuel, smoke, oil mist, dirt dust and other impurities in the fuel. Care should be taken to select the proper viewing head for the fuel used. Additionally, the contaminants that mask UV can be diluted by providing a strong flow of air through the sight pipe to clear a viewing path through the attenuating material. See "Purge Air" on page 10.

It may also be desirable to sight the detector at an area containing fewer masking agents such as near the burner nozzle or near the entrance of the combustion air. Increasing the viewing area of the detector by shortening the sight pipe or by increasing the diameter of the sight pipe can also reduce the attenuating effects of the masking agents.

In general, the UV viewing heads will work well on natural gas and light oil flames. The sighting for both oil and gas flames should be parallel to the axis of the burner and aimed at the root of the flame, as with the IR detector. (See previous section, "IR Detector.") The highest UV intensity occurs near the root of the flame (Fig. 17). In addition, the zone of higher UV intensity does not overlap the same zones of adjacent or opposing burner so that, with proper sighting, discrimination can be achieved.

With low NO_x gas burners, the UV radiation is usually much less in intensity and spread out. Relatively high readings can be obtained from all over the furnace when many burners are in service. This is particularly true when flue gas recirculation is used. There will however, be a relatively stronger signal near the "root" of the flame and

the more intense spot should be located during the aiming or sighting process. This "root" or intense spot may be further out than with the standard gas burner so it is imperative that a swivel mount be used when making sighting adjustments.

Another factor that needs to be considered when aiming the viewing head is the load condition of the boiler. The flames from a burner can be radically different at different loads. This is one of the reasons for choosing an optimum sighting initially that will minimize signal swing due to changing loads.

Self-Checking

The self-check circuitry guards against internal component failure. There are several tasks that require intelligent interaction between the viewing heads and the signal processor. If all of these interactions do not occur properly, the viewing head will not send pulses back to the signal processor and the flame relay will open.

Adjustment of VH Sighting and Gain

NOTE: Adjustment to the viewing head parameters cannot be made unless the viewing head is connected and communicating with the signal processor.

The viewing head should be properly sighted before the setpoints are adjusted. Adjustment can be made easier by a 1/2 in. swivel joint, which Honeywell can supply if one is not available (refer to "Accessories" on page 11).

While the burner is firing, vary the viewing angle while observing the green LED on the connector at the rear of the viewing head. Adjust the viewing angle for the maximum pulse rate, then lock the swivel joint to preserve this mechanical setting. If the green LED pulse rate is very high or very low, see the two paragraphs below. The locked mechanical setting should still be correct when Model 700 viewing heads are interchanged, because inside each Model 700 viewing head the optical axis is aligned with the mechanical axis within $\pm 1/4$ degree. Also, the reading shouldn't change when a viewing head is rotated in the mount.

For the above sighting adjustments to work properly, the flashing rate of the green LED in the connector at the rear of the viewing head must be reasonable. On the -PF (pipe fitting) version, there are no LEDs. The installer must observe the flame signal on the signal processor instead.

A count rate of 16 to 20 is recommended for proper operation. If the displayed count is above 25, the pulses begin to blur together, making changes in the pulse rate difficult to observe.

If the displayed count is less than 8 or 10, it will be difficult to maximize the count by adjusting the viewing head aim, since the pulses occur too infrequently. In such a case the gain should be increased. If the gain is set to a maximum and the count rate persists below 8 or 10, the system can still be made to work reliably as long as the count rate drops significantly when the flame is removed. However,

the setup should be reviewed for proper viewing head aim and sight path to ensure it is optimized.

Orificing

Orifice disks have been used in applications with older viewing heads that did not have adjustable gain in order to reduce the extreme brightness of certain burner flames. The orifice disk kit is part number M-702-6. Orifice disks come with 3/8, 1/4, 3/16 and 1/8 inch diameter holes. Contact the factory for guidance is using orifice disks. The disks are installed with retaining rings in the flange at the edge of the 1/2 inch NPT female pipe thread for the process connection. An internal type retaining ring is first installed by positioning a ring in the machined groove inside the flange opening from the housing side. The orifice disk is then inserted. Use a second retaining ring to hold it in place so that it is sandwiched tightly between the two retaining rings.

If the displayed flame count is 25 or higher when the gain is set to 1, an orificing disc inserted in the back end of the mounting block can be used. Choose a disc that gives a reading of 12 to 24 at a low fire firing rate. The discs have a range of orifice sizes; each size step results in about a 2:1 change in the counts displayed.

Signal Processor User Interface

The 700ACSP and 700DCSP signal processors have a user interface that includes four lights, a two-digit display and twelve push buttons for operation and programming. Each button has at least one specific purpose.

To enter a menu, press and hold the applicable button for 2 seconds. Adjustments to the applicable setpoint can be made via the INCREASE or DECREASE arrow buttons. To store the new setting, press the STORE button until "--" is shown, indicating the value has been accepted.

If no activity occurs for a period of four seconds while the menu value is displayed, it will revert back to the operating display.

To exit a menu at any time without saving changes, simply press the RESET/rE button.

The following describes the functions of the LED indicators, display and push buttons:

Front Panel LED Indicators and Display

- ON SEQ/AUTO SET LED (green):
 - Used in conjunction with the BNR-ON SEQ START/END and BNR-OFF SEQ START/END buttons during the automatic setup process
- OFF SEQ/FAULT LED (green):
 - Used in conjunction with the BNR-ON SEQ START/END and BNR-OFF SEQ START/END buttons during the automatic setup process
 - Indicates a fault condition
- Two digit display
 - When in operating mode, the display indicates the current flame signal, which ranges between 00 and 29
 - Upon power up, indicates whether an IR or UV viewing head is attached and the selected gain setting;

such as r7 (IR with gain of 7) or u5 (UV with gain of 5).

- Indicates various characters during the automatic setup process as well as whether the panel is locked
- FLAME SIG LED (yellow):
 - When a flame is present, LED flashes at a rate proportional to flame signal, except when the pulses are interrupted once per second for viewing head self-checks.
- FLAME ON LED (red):
 - When the flame signal is above the selected value, the LED will be illuminated and the flame relay will be energized.

Push Button Functions

- RELAY ON SETPOINT button:
 - Allows user to select flame on threshold value. When the flame signal is above the selected value, the flame relay will be energized. Used in conjunction with the INCREASE, DECREASE and STORE buttons (range of 00 to 29).
- LOAD FACTORY DEFAULTS button:
 - Used to restore all settings to the factory default values
- ↑ INCREASE button:
 - Used to increase parameter value when in programming mode
- RATIO (%) RELAY OFF/RELAY ON button:
 - Used along with the INCREASE, DECREASE and STORE buttons to set the RELAY OFF setpoint at a percentage of the RELAY ON setpoint. Adjustable from 20% to 80%.
- STORE button:
 - Stores new parameter values during programming
 - After making changes "--" will be displayed indicating the new values are accepted and stored
- ↓ DECREASE button:
 - Used to decrease parameter value when in programming mode
- BNR-ON SEQ START/END button:
 - Used to initiate and proceed through the automatic parameter setup sequence, which includes the RELAY ON, RATIO (%) and GAIN settings (the FFRT, mA output and communication address must be set manually)
- BNR-OFF SEQ START/END button:
 - Used during the automatic parameter setup sequence
- ACCEPT RATIO/SET GAIN button:
 - Allows user to set the viewing head gain in conjunction with the INCREASE, DECREASE and STORE buttons
 - Used in conjunction with the BNR-ON SEQ START/END and BNR-OFF SEQ START/END buttons during the automatic setup process
- FFRT 1/2/3 SEC OPTION button:
 - Used to set the FFRT timing along with the INCREASE, DECREASE and STORE buttons
- 0-20MA 4-20MA OPTION button:
 - Used in conjunction with the INCREASE, DECREASE and STORE buttons to select the proportional mA output for the flame signal
- RESET rE button:
 - Resets a lockout condition
 - Also used to exit a menu while programming

- Used to set the Modbus address along with the INCREASE, DECREASE and STORE buttons

Manual Setup of Setpoints

The keypad of the signal processor is used to set the IR/UV GAIN, RELAY ON, RATIO % (Relay Off), FFRT and mA output option setpoints. The following section describes this process. Also refer to Fig. 23, 24, 25, 26 and 27.

Setting the Viewing Head Gain

The gain of the IR and UV viewing heads can be adjusted. In addition to the information in this section, refer to Fig. 27. At power-up, the 700 signal processors display codes to tell the operator what type of viewing head and what gain is being used. Default values are “r5” for the IR viewing head and “u5” for the UV viewing head. The “r” or “u” denote IR or UV viewing heads, respectively, while the numeric digit indicates the current gain setting. The gain can be adjusted from 1 to 9 with a gain of 5 being the factory default gain.

To change the gain, press and hold the SET GAIN button for two seconds until the current value is displayed. Use the INCREASE and DECREASE buttons to change the setting as appropriate while the value is displayed. To store the new setting, press the STORE button until “- -” is shown, indicating the value has been accepted.

If no activity occurs for a period of four seconds while the value is displayed, the display will return to the operation mode without saving the new setpoint.

To exit the menu at any time without saving changes, simply press the RESET/rE button.

The gain is live; changes are effective immediately, but if the displayed gain value is not stored (by pressing STORE), and no other buttons are pressed, the processor returns to the previous setting after four seconds.

Relay On Setpoint

The two numeric digits on the Model 700 signal processor normally display the incoming count during operation; that is, the number of pulses that arrive between self-check pulses. This count ranges from 00 to 29.

Refer to Fig. 23 for a flowchart of setting the Relay On setpoint. Press and hold the RELAY ON SETPOINT key for two seconds to access this setpoint. The RELAY ON SET POINT value will be displayed. If no further keys are pressed, this display will disappear in four seconds and the incoming count will again be displayed. If the RESET key is pressed, the display will return immediately to displaying the incoming count.

While the RELAY ON SET POINT is displayed, you may increase or decrease the setting by using the INCREASE and DECREASE arrow keys. To store the new setting, press the STORE button until “- -” is shown, indicating the value has been accepted.

To exit the menu at any time without saving changes, simply press the RESET/rE button or wait 4 seconds until the display reverts to the incoming count value. To extend the display time, press the RELAY ON SETPOINT button again; the display will time out for four seconds after the key is released if no other buttons are pressed.

The displayed value of the RELAY ON SET POINT is live; that is, if the relay is off and the adjusted value falls below the current flame signal count, the relay will turn on immediately (FFRT settings are ignored). This immediate response can be seen if the count is low and the RELAY ON SET POINT is set above it; if the RELAY ON SET POINT is then adjusted down to the count level, the FLAME ON relay will be energized.

Testing for proper operation

The system must be tested after commissioning to ensure that the flamecount produced from background radiation is less than the flame off threshold when the monitored flame is extinguished. (ex. When target flame is extinguished, flamecount drops and flame relay opens).

Proper flame scanner setup is required to ensure safe operation.

Background Burner Flame Test

Background burner flame radiation may be present when monitoring inside of a large furnace with multiple burners.

Below are example steps for testing and resolution.

1. Turn off monitored flame, while background flames are still present. Operate the background burner(s) at most intense flamecount. Flame relay should be open.
2. Restart monitored flame, and verify that flame relay closes.
3. Turn off monitored flame while background flames are present. Verify that flame relay opens.
4. If the flamerelay remains closed, then you are incorrectly detecting background flames.
5. If the scanner is detecting background flames, use one or more of the following suggestions to correct, and repeat test steps to ensure scanner is no longer sensing background flames:
 - Reduce UV, or IR gains.
 - Re-position viewing head to sense high frequency of target flame, and low frequency background flame
 - Re-position head to view high intensity of monitored flame, and low intensity of background flame.
6. Re-view setup process and make adjustments as necessary.

IR Hold In Test

It is possible to setup the scanner so that hot refractory is detected as flame, causing the flame relay to “hold in” when flame has been extinguished. It is important to setup the scanner system properly so that background flame or refractory glow does not indicate flame presence when the monitored flame is extinguished.

Below are example steps for testing and resolution of hot refractory hold in.

1. Operate the burner until the refractory reaches its maximum temperature. If the installation is a multi-fuel burner, burn the heavier fuel that is most likely to reflect, bend or obscure the hot refractory steady infrared radiation.
2. When the maximum refractory temperature is reached, close all manual shutoff valves, or open the electrical circuits of all automatic fuel valves.
3. Visually observe the monitored flame, and note how long it takes from the time of flame loss, to when the scanner flamecounts fall below the off threshold, turning off the flame relay. If this time is longer than the FFRT time, then the scanner is sensing hot refractory.
4. Immediately terminate the firing cycle. Lower the setpoint to the operating controller, or set the Fuel Selector Switch to OFF. Do not open the master switch. NOTE: Some burners continue to purge oil lines between the valves and nozzles even though the fuel valves are closed. Terminating the firing cycle (instead of opening the master switch) allows purging the combustion chamber. This reduces a buildup of fuel vapors in the combustion chamber caused by oil line purging.
5. If the burner scanner is detecting hot refractory, use one or more of the following suggestions to reduce IR level, and repeat test steps to ensure scanner is no longer sensing hot refractory:
 - Reduce IR gain setting.
 - Add an orifice to the flame scanner (see accessories).
 - Re-sight the scanner at a cooler, more distant part of the combustion chamber. Make sure the detector properly sights the monitored flame.
 - Try lengthening the sight pipe or decreasing the pipe diameter size.

XRAY Radiation

Xray radiation does not affect signal processor, or viewing head IR sensor performance, and does not adversely affect viewing head tube sensor performance under the following conditions:

Radiation Source of 65 Curie Iridium 192
 Distance > 5'
 Exposure type Direct
 UV tube gain set to default
 Flame off threshold >600

If viewing heads are subjected to more severe conditions, system must be tested to ensure that radiation does not cause flame-counts above flame off threshold. If this occurs, flame off threshold must be increased, UV tube gain must be reduced, or lead shielding must be used.

Ratio (%) Relay Off/Relay On Setpoint

For a flowchart of this setpoint process, refer to Fig. 24. The key labeled RATIO (%) RELAY OFF/RELAY ON is used to set the RELAY OFF SET POINT at a percentage of the RELAY ON SET POINT. This percentage is adjustable from 20% to 80%. For example, if the RELAY ON SET POINT is set to 16 and the RATIO (%) is set to 50% (the factory default values) the relay will energize if the displayed count goes to 16 or higher and de-energize when the count drops to 08 or less for one to three seconds,

depending on the FFRT (Flame Failure Response Time) setting. The adjustment of the RATIO setting is live. Adjustments will cause the Flame Relay to de-energize immediately, ignoring FFRT settings.

To access this setpoint, press and hold the ACCEPT RATIO/SET GAIN button for 2 seconds until the current value is displayed. While the value is displayed, adjustments may be made via the INCREASE or DECREASE arrow buttons. To store the new setting, press the STORE button until "--" is shown, indicating the value has been accepted.

If no activity occurs for a period of four seconds while the value is displayed, the RATIO display will disappear and the old ratio setpoint will take effect.

To exit the menu at any time without saving changes, simply press the RESET/rE button.

Setting FFRT (Flame Failure Response Time)

To access the FFRT setpoint, press and hold the FFRT 1/2/3 SEC OPTION button for 2 seconds until the current value is displayed. Refer to Fig. 25 for the setup flowchart. The FFRT can be set at 1, 2 or 3 seconds. While the value is displayed, adjustments may be made via the INCREASE or DECREASE arrow buttons. To store the new setting, press the STORE button until "--" is shown, indicating the value has been accepted.

The FFRT changes are not live; they take effect only if the STORE button is pressed. FFRT values do not relate to the RELAY ON SETPOINT and RATIO (%) / RELAY OFF values. Therefore, during automatic setup, if the AUTO SET LED is on, confirmation is not needed to change the FFRT setting.

If no activity occurs for a period of four seconds while the value is displayed, the FFRT display will disappear and the old setpoint will take effect.

To exit the menu at any time without saving changes, simply press the RESET/rE button.

0/4-20mA Output Option

An analog output current is provided for operating a remote meter or other instrumentation. The load resistance should not exceed 360 Ohms for the Model 700 signal processors. The resistance can be chosen to give the desired voltage swing. For example, if 2V is desired for a 20 mA output, a 100 Ohm resistor would be used. Fig. 26 contains a flowchart for the mA output setup.

The analog current output selections are 0 to 20 milliamps, or from 4 to 20 milliamps. Selection of the applicable range is made by pressing and holding the 0-20 MA/4-20 MA OPTION button until the current value is shown. 02 denotes the 0-20mA selection while 42 denotes the 4-20mA selection (the default value). While the value is displayed, it may be changed via the INCREASE or DECREASE arrow buttons. To store the new setting, press the STORE button until "--" is shown, indicating the value has been accepted.

Confirmation is not requested if the 0-20/4-20 setting is changed when AUTOSSET LED is on.

The 0/4–20mA output option is live; the operative range changes as soon as the displayed selection is changed. However, the value must still be saved via the STORE button in order to be saved in the signal processor's EEPROM.

To exit the menu at any time without saving changes, simply press the RESET/rE button or wait four seconds.

The analog current output is scaled according to the RELAY ON setting. It is scaled so that, if the counts coming in are at a count rate equal to the RELAY ON setting, the current output is approximately 13 MA when the range selected is 0–20 MA, and about 14.6 MA when the range selected is 4–20 MA.

Note that the actual maximum level for the current output is 19.8 MA.

Automatic Setup of Setpoints

With this feature, the Model 700 signal processors set the RELAY ON SET POINT, the RATIO % (Relay Off), and the UV/IR GAIN automatically. Calculations for these settings are carried out in the signal processor as the operator takes the system through BURNER ON and BURNER OFF sequences. Fig. 20, 21 and 22 flowchart the automatic setup sequence.

The FFRT (flame failure response time) and the 0/4–20mA output option must be manually setup after the automatic setup process is complete. Refer to the Manual Setup of Setpoints section and Fig. 25 and 26. for details on setting these 2 parameters.

Before starting the automatic setup sequence, adjust the RELAY ON SET POINT to get the FLAME ON relay to energize.

Press BNR-ON SEQ START/END key for two seconds. If the FLAME ON relay is de-energized, the display will show "bo" (burner off); press RESET to clear this. If the FLAME ON relay is energized, the ON SEQ LED will start flashing slowly and the numeric display will start counting down from 59 while the processor takes data at one reading per second. The FLAME ON relay will remain energized if the flame is present, according to the current settings, until valid new values are obtained. To end the data sampling, press the same button, BNR-ON SEQ START/END, again, but ensure that an adequate number of data samples has been taken. At least 30 seconds of BNR-ON data sampling is recommended; ten seconds is a minimum. The software will not respond to a second press of the button for 10 seconds. RESET may also be pressed while the data sampling is occurring; the data sampling process will be aborted and the old values will remain in effect.

After BNR-ON data sampling is complete, the OFF SEQ LED flashes. Turn off the burner and immediately press the BNR-OFF SEQ START/END key (a two-second press is not required). The displayed timer then counts down from 29. This process may be interrupted, but at least 15 seconds of BNR-OFF data sampling is recommended. The data sampling process can be aborted by pressing RESET, in which case the data for both BNR-ON and BNR-OFF will be discarded and the previous values will remain in effect.

If the data is good, that is, the computed ratio is 71% or less when BNR-OFF data sampling is complete, the display shows the ratio in percentage for one second, followed by "--" to indicate a successful setup. The signal processor then turns on the AUTO SET LED to verify that the values stored internally were derived from the BNR-ON/BNR-OFF data sampling sequence.

If the data received is marginal, with the computed ratio ranging from 72% to 80%, the display alternates between "AC" and the computed ratio, for example, "AC" and "75." Press either the ACCEPT RATIO or RESET keys. If ACCEPT RATIO is pressed, the display responds with "--", the ratio is stored, and the AUTO SET LED is turned on. If RESET is pressed, the display returns to the counts, both of the AUTO SETUP LEDs are turned off, and the old setpoints are used.

If the ratio computed as a result of BNR-ON and BNR-OFF data sampling is higher than 80%, the display will show "UA" (unacceptable), alternating with the unacceptable ratio. For example, if the computed ratio is 93%, the display would alternate between "UA" and "93." RESET must be pressed to clear this; the old values for RELAY ON and RATIO will remain in effect.

The values can be worse than just unacceptable. If the flame relay de-energizes while reading BNR-ON values, the display will show "bo," and data-taking will be aborted. Other faults, such as a BNR-ON flame signal that is too low to use, or BNR-OFF readings that are too close to the BNR-ON readings, can result in "rE" being displayed. RESET should then be pressed.

The signal processor also adjusts the viewing head gain during the BNR-ON and BNR-OFF data sampling sequence. Normally, after the sequence, the display should read about 20, because the gain has been adjusted to give this reading. If it is less than about 18, you should find that the gain has been set to 9; if it is more than about 22, you should find that the gain has been set to 1.

Once the values have been stored through this sequence, you can check the RELAY ON SET POINT, the RATIO, or the GAIN by pressing the appropriate key for two seconds. However, if you attempt to change these values by pressing the INCREASE or DECREASE keys, the display will show "CF" (confirm), and the AUTO SET LED will flash rapidly. To confirm the desired change, press the RELAY ON SET-POINT key, the RATIO key, or the SET GAIN key a second time. To discontinue any changes, press the RESET key or simply wait four seconds for a time out to occur.

The user confirms they wish to make changes, the values will change when you use the INCREASE or DECREASE keys. Meanwhile, the AUTO SET LED will be flashing. The AUTO SET LED will de-energize only if the changed values are stored; if the changed values were not stored, the AUTO SET LED will light and the old values will remain in effect.

If values were obtained automatically, that is, if the AUTO SET LED is on and the BNR-ON SEQ START/END key is pressed, the display will also show "CF." If the BNR-ON SEQ START/END key is pressed again, the signal processor will begin the BNR-ON data sampling sequence.

Loading Factory Defaults

Fig. 19 shows the flowchart for restoring default values. Pressing and holding the LOAD FACTORY DEFAULTS button will result in the values shown in Table 3 being loaded and stored in EEPROM. During the automatic setup sequence, if the AUTO SET LED is on when the LOAD FACTORY DEFAULTS key is pressed, "CF" will be displayed. Press the LOAD FACTORY DEFAULTS key again to confirm the change, or press RESET to abort the change. If the factory defaults are loaded, the AUTO SET LED will be turned off.

Table 3. S70X/S80X Default Settings

Relay on setpoint	16
Ratio (%) relay off/relay on	50%
FFRT (Flame Fail Response Time)	1 sec
0-20mA/4-20mA OPTION	4-20mA
UV/IR Gain	5
Communication address	0

Panel Lock

A pattern of key presses will result in the panel being locked so as to block any changes to the values stored in the signal processor. With the panel locked, values may be examined, but the signal processor will not respond to the STORE key.

The panel should be locked after the setpoints are set. Contact the factory to obtain the procedure to lock or unlock the panel.

MODBUS COMMUNICATION

The 700ACSP and 700DCSP signal processors are capable of communication with Flametools software running on a Microsoft® Windows® PC, S7999D touch screen or other device that supports Modbus RTU protocol. Both Flametools and the S7999D include graphic user interfaces. Other devices will require the user to generate an interface. The data transmitted to and from the 700ACSP/700DCSP is over two twisted pairs that are differentially driven and received according to the RS-422 standard. Honeywell offers a RS485/422 to USB converter to use in conjunction with the 700ACSP/700DCSP signal processors. The Honeywell part number is COMM0D.

Refer to Fig. 8 and Fig. 9 for a typical communication wiring and addressing scheme as well as the required wiring of the COMM0D communication converter.

The 700ACSP and 700DCSP signal processors have two modular phone jacks for RS-422 communications. The jacks are wired in parallel so that point-to-point cables can be jumped from unit to unit to interconnect multiple

Model 700 signal processors. The RS-422 interface IC is a MAX489. The ICs can drive up to quantity 32, Model 700 signal processors on the same bus.

For communication with external controls or computers, refer to Table 4 for the Modbus registers map.

Communication Setting

700ACSP and 700DCSP can only communicate via Modbus RTU protocol, with the following configuration:

- 9600 baud
- 8 data bits
- no parity
- 1 stop bit

NOTE: Default protocol must be changed in order to use Modbus communication. It may be set for Modbus by using key sequence below at the front panel of the 700 as follows:

1. Press and hold BNR-OFF SEQ START/END button for 2 seconds.
2. Press up arrow to change setting from P0 to P1.
3. Press STORE.

The factory default Modbus address of the 700ACSP and 700DCSP is 0 and must be changed to a number between 1 and 32 to establish communication between the signal processor and the host control. When more than one signal processor is in the network, ensure that each signal processor has a unique Modbus address within the range of 1 to 32.

Modbus RTU Function Supported

Four Modbus functions are supported:

- 01 Output coil read
- 03 Holding register read
- 06 Preset single holding register
- 16 Preset multiple holding register

NOTES:

- Before Model 700 signal processors are connected to the RS-422 bus, their individual Modbus addresses must be set to differing values between 1 and 32.
- The RESET button on front of the 700ACSP or 700DCSP signal processors is used to set the Modbus address.
- Press and hold the RESET button for two seconds and the current address will appear. It may be changed with the up or down arrow keys.
- Pressing the STORE button will store the new address.

Table 4. MODBUS registers map.

Register	Name	Description	Minimum	Maximum
40001	FLAMECOUNT	Flame count of active viewing head (read only)	0	3425
40002	PROCSTATUS	Processor status bitmask (read only) bit 1: flame on relay status (1=relay energized, 0=off) bit 2: Processor Lockout status (0 =lockout, 1=not lockout) bit 3: Panel access disabled (1=disabled, 0=enabled) bit 4: 4 - 20 ma output (0=0 to 20, 1=4 to 20)	0	255
40003	FLAMEON	Flame On setpoint (read/write)	3 (S70X)	29
40007	OUTPUTGAIN	Gain of the 0/4-20mA output (read/write)	20	80
40010	IRGAIN	IR sensor gain setting (read/write)	1	9
40012	UVTGAIN	UV tube gain setting (read/write)	1	9
40017	TYPE	Viewing head type bitmask (read only) bit 0: UV viewing head bit 1: IR viewing head	-	-
40021	TIMEDELAY	Time Delay (read only) =1 for 700XXSP	1	2
40022	FFRT	Flame failure response time setting in seconds (read/write)	1	3
40023	VERSION	Firmware version (read only)	-	-
40024	MODEL	Model number (read only)	-	-
40084	ERRORCODE	Error code (read/write) NOTE: writing a non zero number to this register is not allowed	-	-
40085	BAUD	Baud rate setting (bits/second). Only affects RS-485 communication, not IRDA. (read, write) 96=9600 (default), 192=19200. The SP and the master device must have the same baud settings.	96	192
40086	PARITY	Parity setting. Only affects RS-485 communication, not IRDA. (read/write) 0= none (default), 1=odd	0	1
40087	ADDRESS	Modbus address used by RS-485 and IRDA (read/write). Each device must have a unique address.	0	247
40089	PROTOCOL	Protocol (read/write) 0=Honeywell protocol, 1=Modbus protocol	0	1

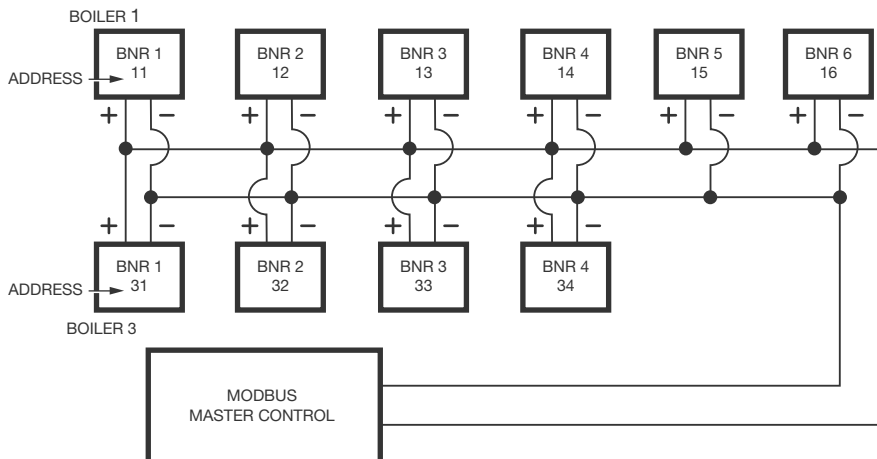

NOTES: A CONVERTER MAY BE NECESSARY FOR COMMUNICATION WITH THE MODBUS MASTER CONTROL.

USE SHIELDED CABLE FOR COMMUNICATION WIRING.

DRAWING IS FOR GENERAL REFERENCE ONLY.

FOR RS422 COMMUNICATION WITH THE 700ACSP OR 700DCSP, AN RJ11 CONNECTOR WITH 5 WIRES FROM EACH SIGNAL PROCESSOR WILL BE REQUIRED (RDA-, RDB+, TDA-, TDB+, GND), FOLLOWING POLARITY FROM EACH SIGNAL PROCESSOR.

M34457

Fig. 8. Typical Communication Wiring and Recommended Addressing.

NOTE: Refer to Fig. 9 for converter to RJ11 wiring details.

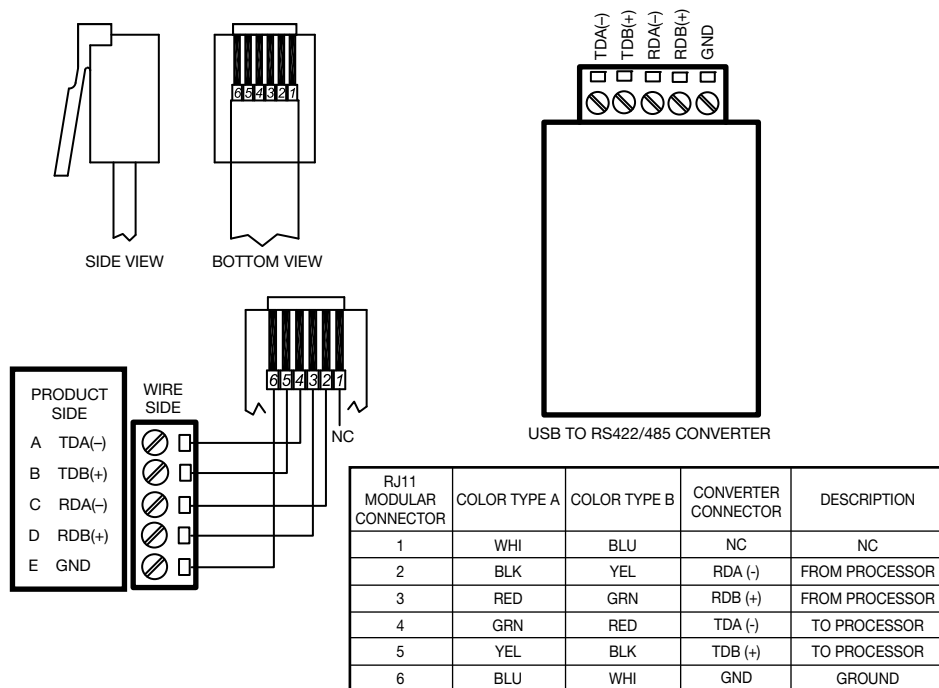

CAUTION: THE ORDER OF THE COLORS IN THE CABLE CAN BE TYPE A OR TYPE B. CHECK COLORS AT THE CONNECTOR.

NOTES:

SELECT THE APPROPRIATE DIP SWITCH SETTINGS FOR RS-422 COMMUNICATION PER THE VENDOR'S INSTRUCTION SHEET.

RJ11 CONNECTOR IS CUSTOMER SUPPLIED AND WIRED.

SOFTWARE DRIVERS MAY BE DOWNLOADED FROM B&B ELECTRONICS' WEBSITE.

M33831A

Fig. 9. COMMOD Communication Converter Wiring.

TROUBLESHOOTING

Lockout or Faulty VH Indication

If the viewing head produces any pulses during the last one third of the self-check time, the relay will immediately de-energize, the display will show “LO” (lockout), and the FAULT LED will flash on and off rapidly. Exit lockout by pressing RESET.

If a pulse or pulses come in during the last one third of the self-check time while the automatic data sampling is taking place, the automatic process will be aborted, the relay will be de-energized if it was energized, the display will show “LO” (lockout), and the FAULT LED will flash on and off rapidly. Press RESET to exit this.

If a viewing head is disconnected, the display will show “L1.” Reconnect the viewing head and press RESET.

If the signal processor displays “EE” upon power up, it is an indication that the EEPROM stored data for the viewing head does not match for the currently connected viewing head. For further information on this condition, refer to the Parameter Match Error Section below.

Parameter Match Error

If the signal processor displays “EE” upon power up, it is an indication that the EEPROM stored data for the viewing head does not match for the currently connected viewing head. This error can occur when a different model viewing head is connected to the signal processor than was previously connected. As a result, the signal processor discards the previous stored parameters and loads factory defaults, except the RELAY ON SETPOINT is set to 31.

Setpoint values and other parameters plus error-checking codes are stored in EEPROM (Electrically Erasable Programmable Read Only Memory) in the signal processors. This data is then error-checked when it is read at power up. If the data does not match exactly what was previously stored, the signal processor discards all data, displays “EE”, and loads factory defaults. The RELAY ON SETPOINT is set to 31. Since the flame count cannot go

this high, the flame relay cannot be energized. The signal processor can be reset by changing the RELAY ON SETPOINT to a reasonable value or by pressing LOAD FACTORY DEFAULTS.

Panel Lock with No VH Connected

The signal processor requires continuous communication with the connected viewing head. If the viewing head is disconnected, communication will be lost and the display is made inoperative where no settings can be examined or changed. To correct this condition, reconnect the viewing head to the signal processor and cycle power.

Grounding and Shielding

See “Grounding and Shielding” on page 3. for further troubleshooting help in regards to proper grounding and shielding techniques.

MAINTENANCE

(UV tube models Only)

The UV sensor has a limited lifespan. Under extreme conditions, the lifespan can be as low as 10,000 hours. However in the most favorable conditions, the lifespan is 50,000 hours or more. The service life of the UV sensor is considered terminated when the sensitivity becomes lower than 50% of the initial value.

A monthly sensitivity check is suggested to determine if the UV sensor’s life is terminated. The reading of the signal processor digital display should be compared to the initial reading of the unit when it was installed. Ensure similar burner fire conditions of the application, and that the same gain settings of the viewing head, are used during each sensitivity check. If it is determined that the sensitivity is below 50% of the initial value (terminated life of the sensor), the sensor should be replaced.

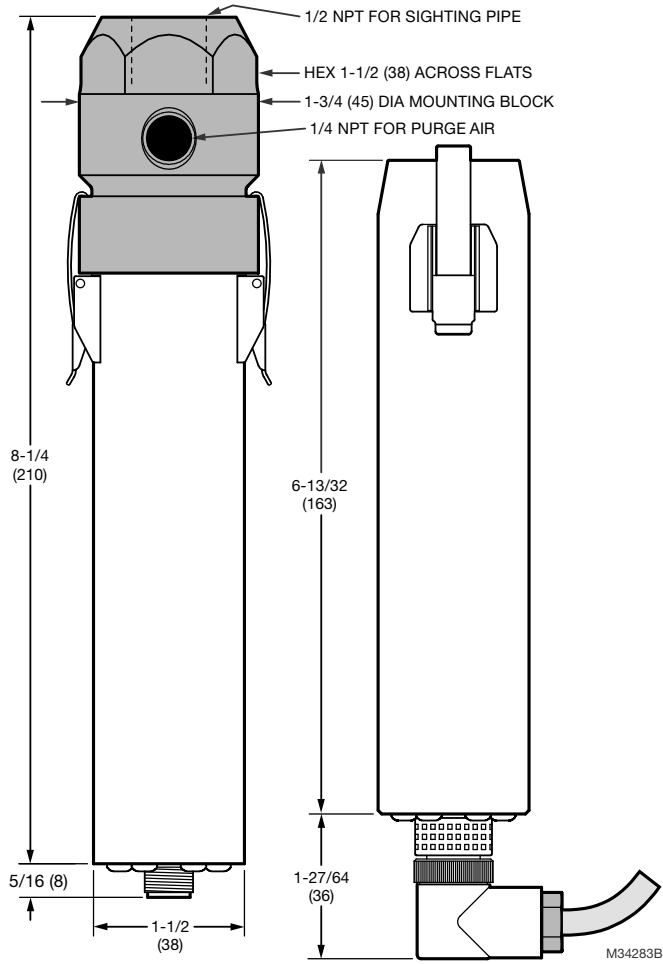

Fig. 10. Models S702 and S706 Viewing Heads.

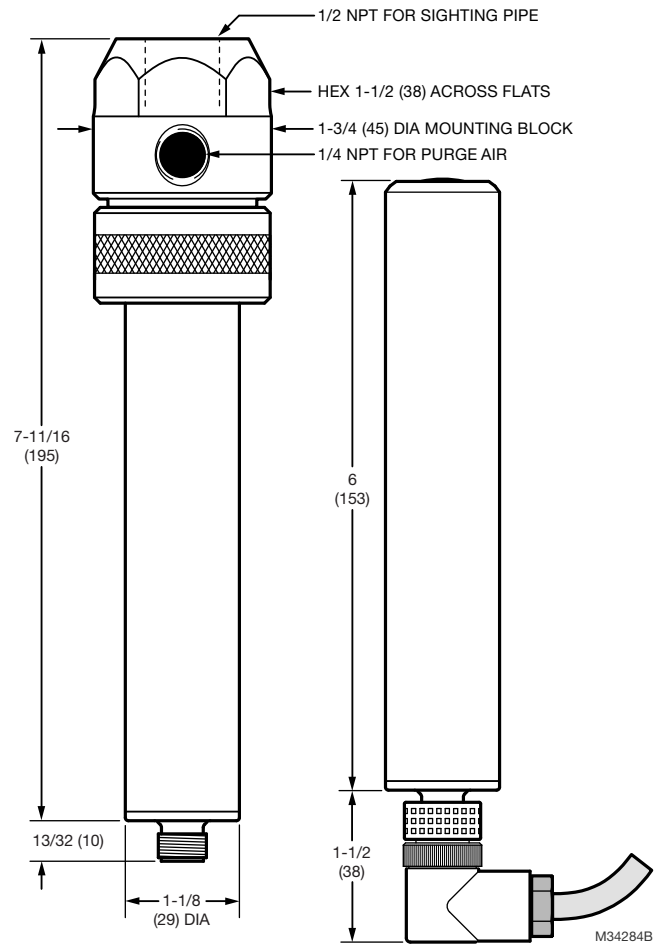

Fig. 11. Models S802 and S806 Viewing Heads.

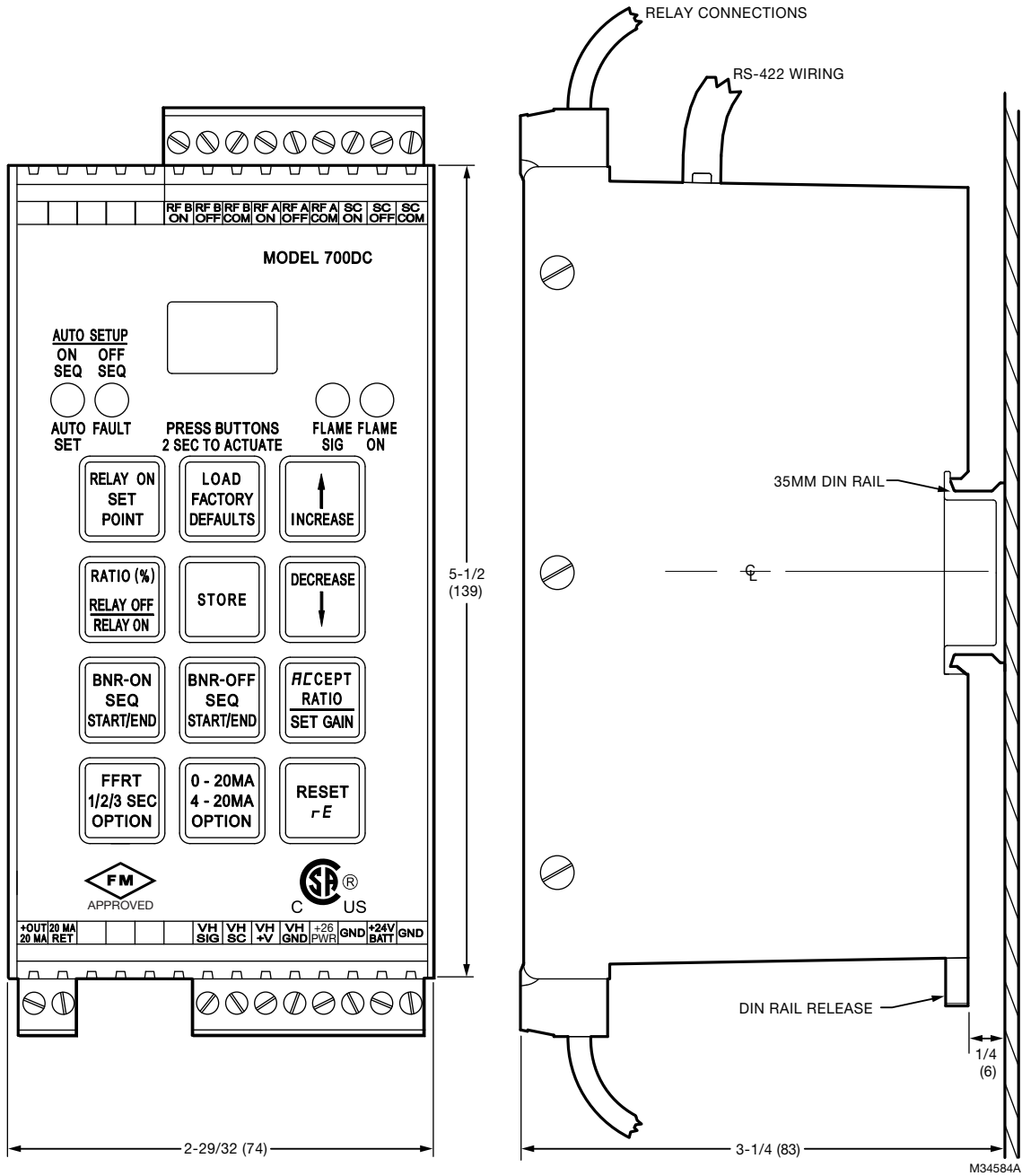

Fig. 12. Model 700DCSP Signal Processor.

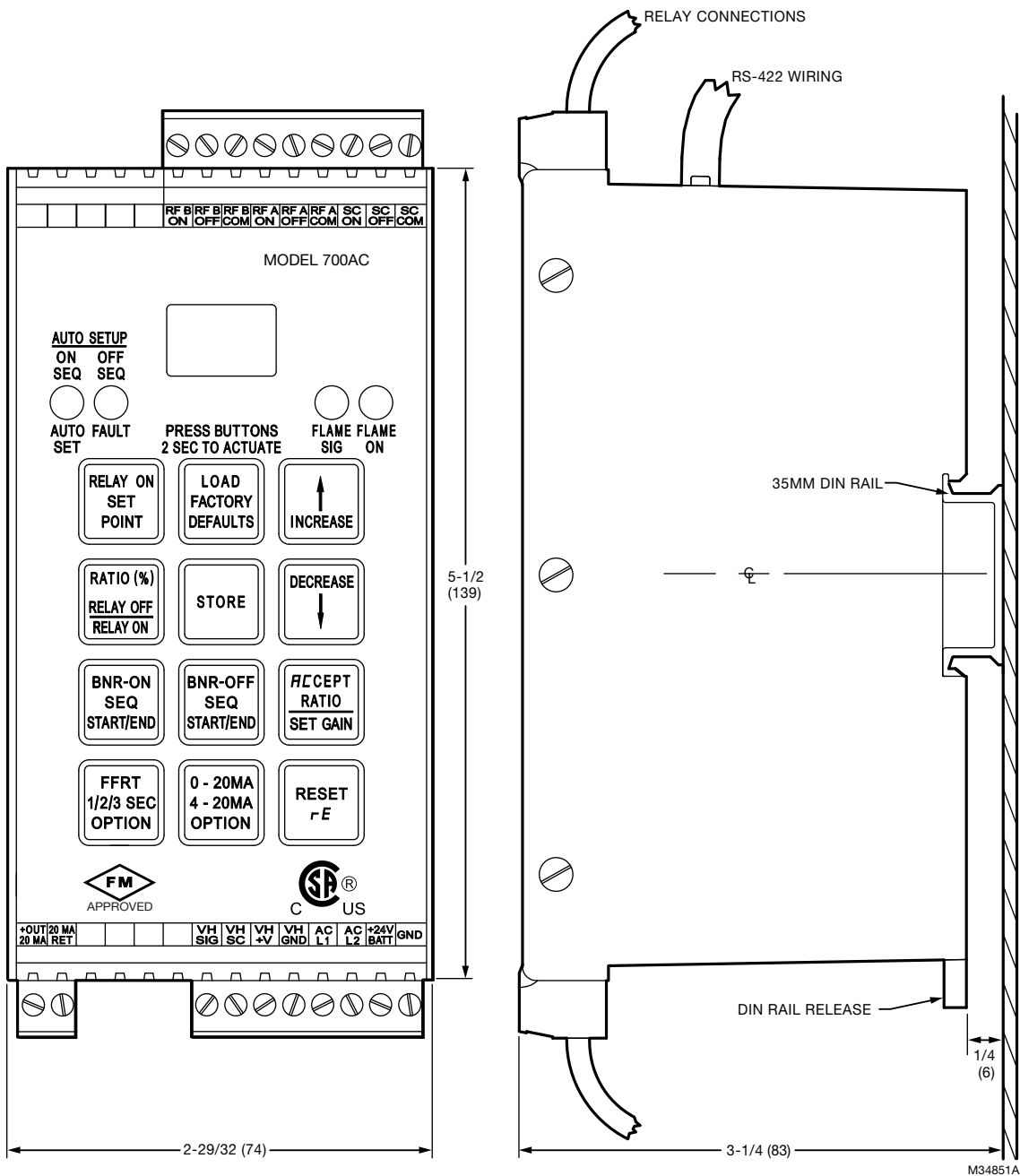

Fig. 13. Model 700ACSP Signal Processor.

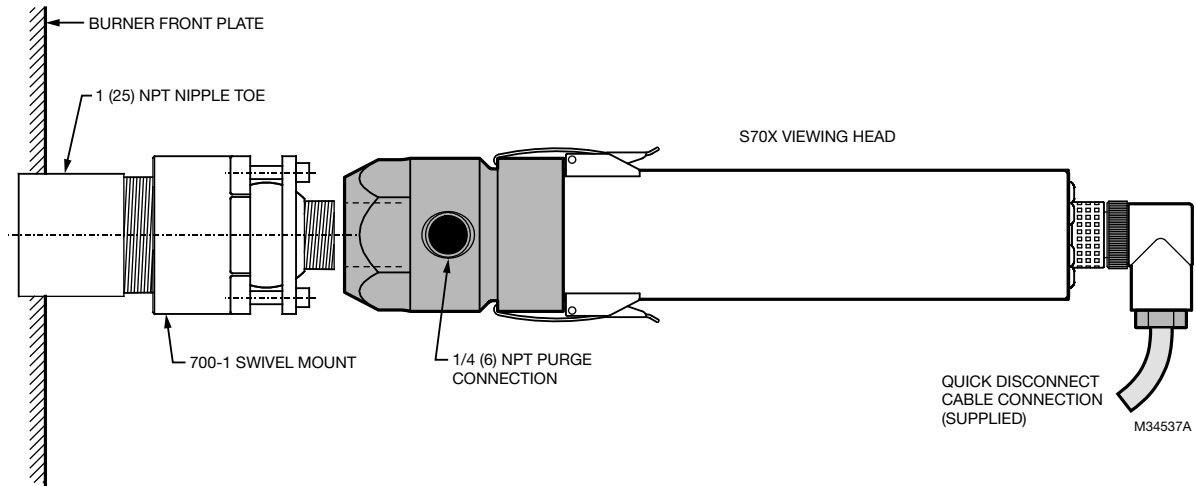

Fig. 14. Viewing Head Mounting Example.

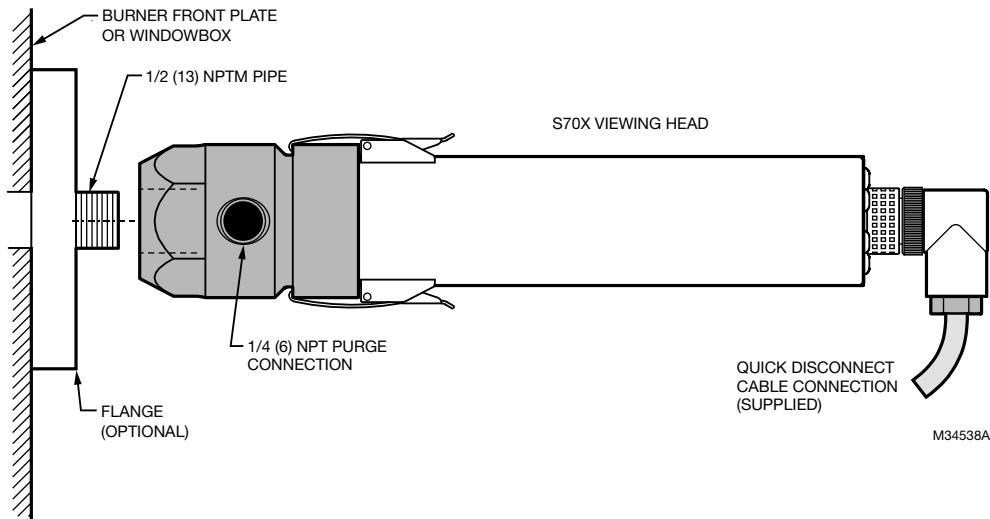

Fig. 15. Viewing Head Mounting Example.

Mounting Examples

Purge air should be provided via the purge air connection to reduce conducted heat and to keep the sight pipe and viewing head lens free of dirt and debris. Refer to “Purge Air” on page 10 for requirements. For electrical isolation reasons, the purge air line should be installed using and insulating material, such as a rubber hose, in between the purge air line and the viewing head. Note that an extension pipe may be required to locate the viewing head further from the burner front plate to avoid high

temperatures. Additionally, an Ultem replacement insulating mounting block is available for all models, which is rated for 320F (160C) continuous service. Also available are cooling jackets which are used with vortex coolers. The Honeywell Ultem R-518-13 nipple or R-518-PT13/R-518-PT13L locking coupler adapter and R-518-CL13-HTG locking coupler can also be used for heat insulation reasons. Refer to the Accessories section of this document for accessory part numbers.

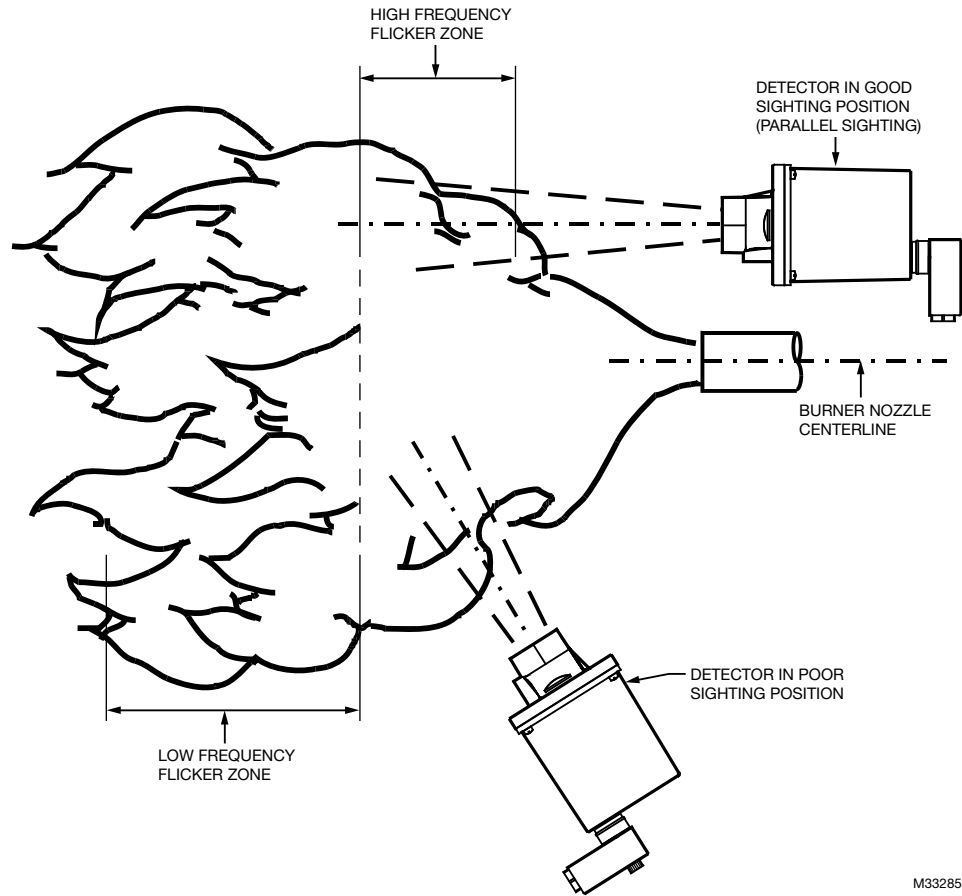

Fig. 16. IR Viewing Head Location

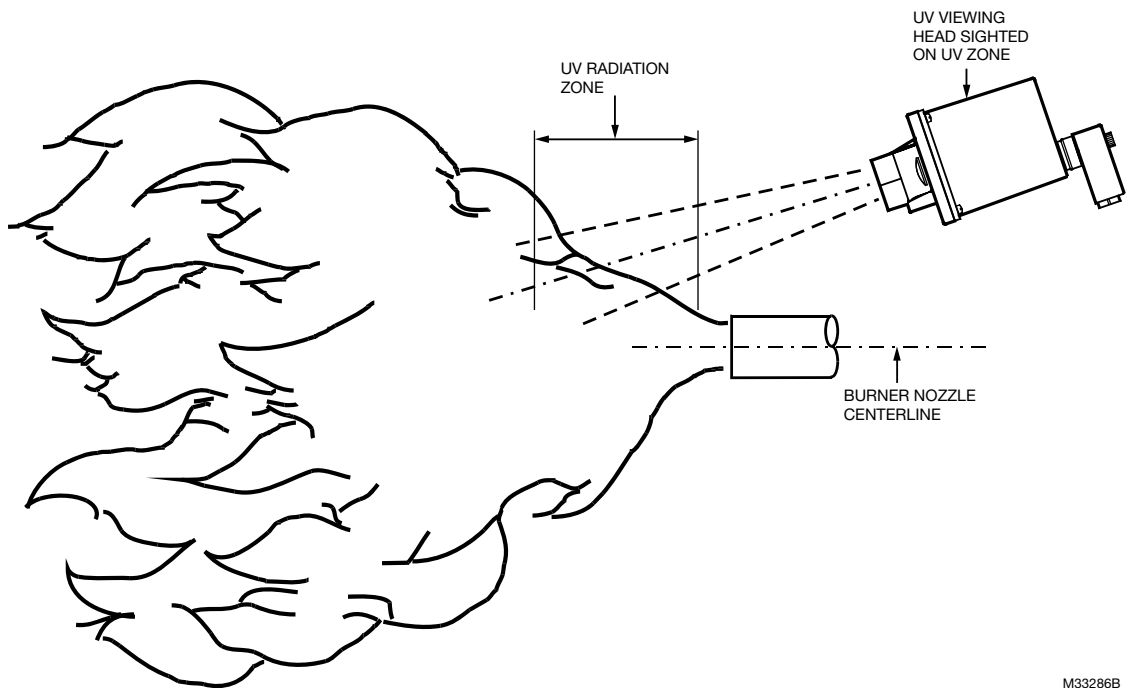

Fig. 17. UV Viewing Head Location

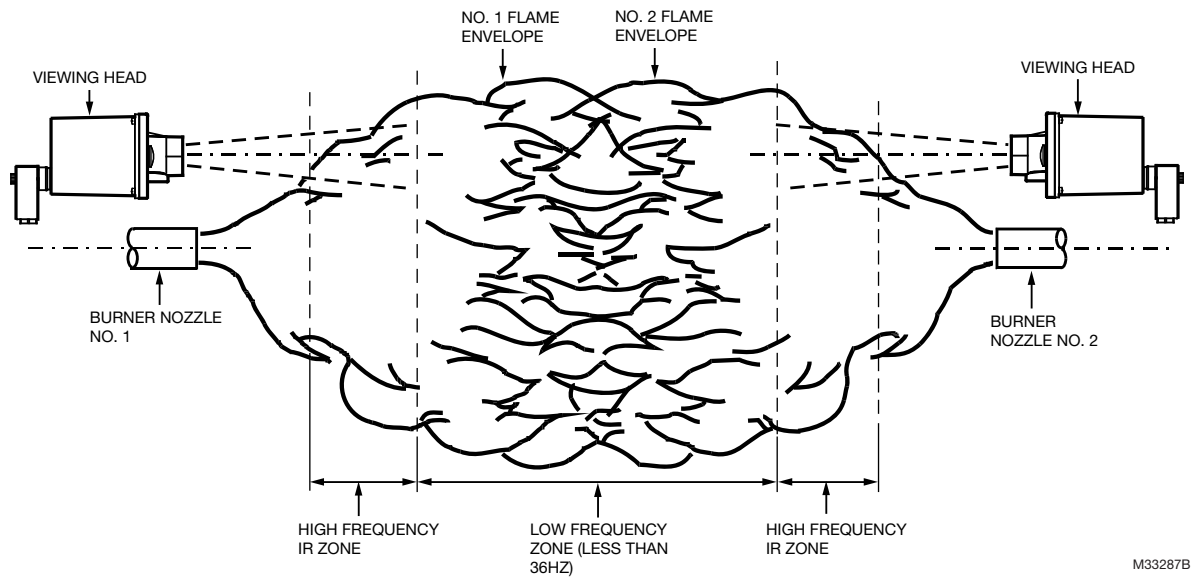

Fig. 18. Opposed Fired Viewing Head Sighting

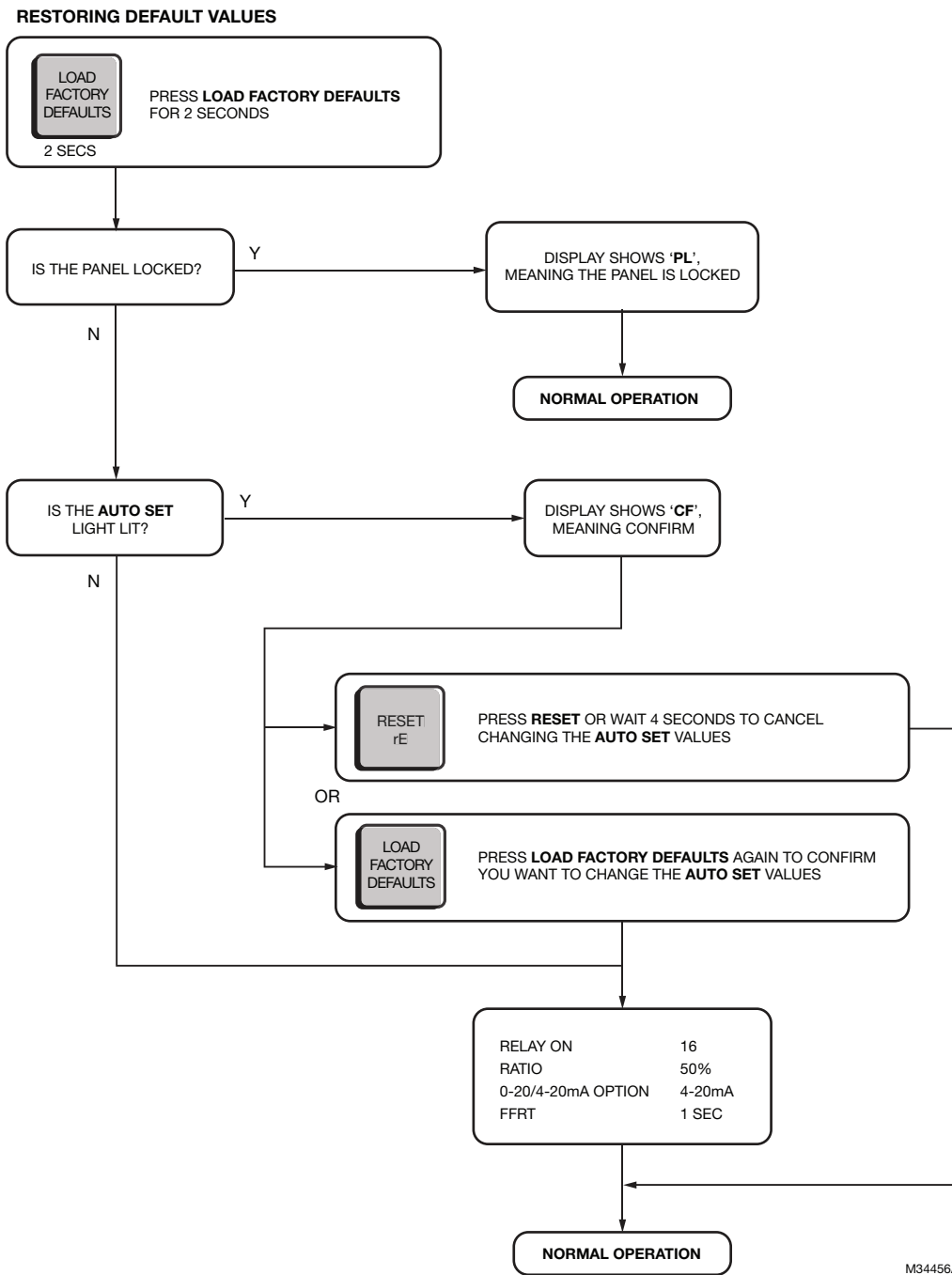

Fig. 19. Flow Chart 1 - Setting Factory Defaults.

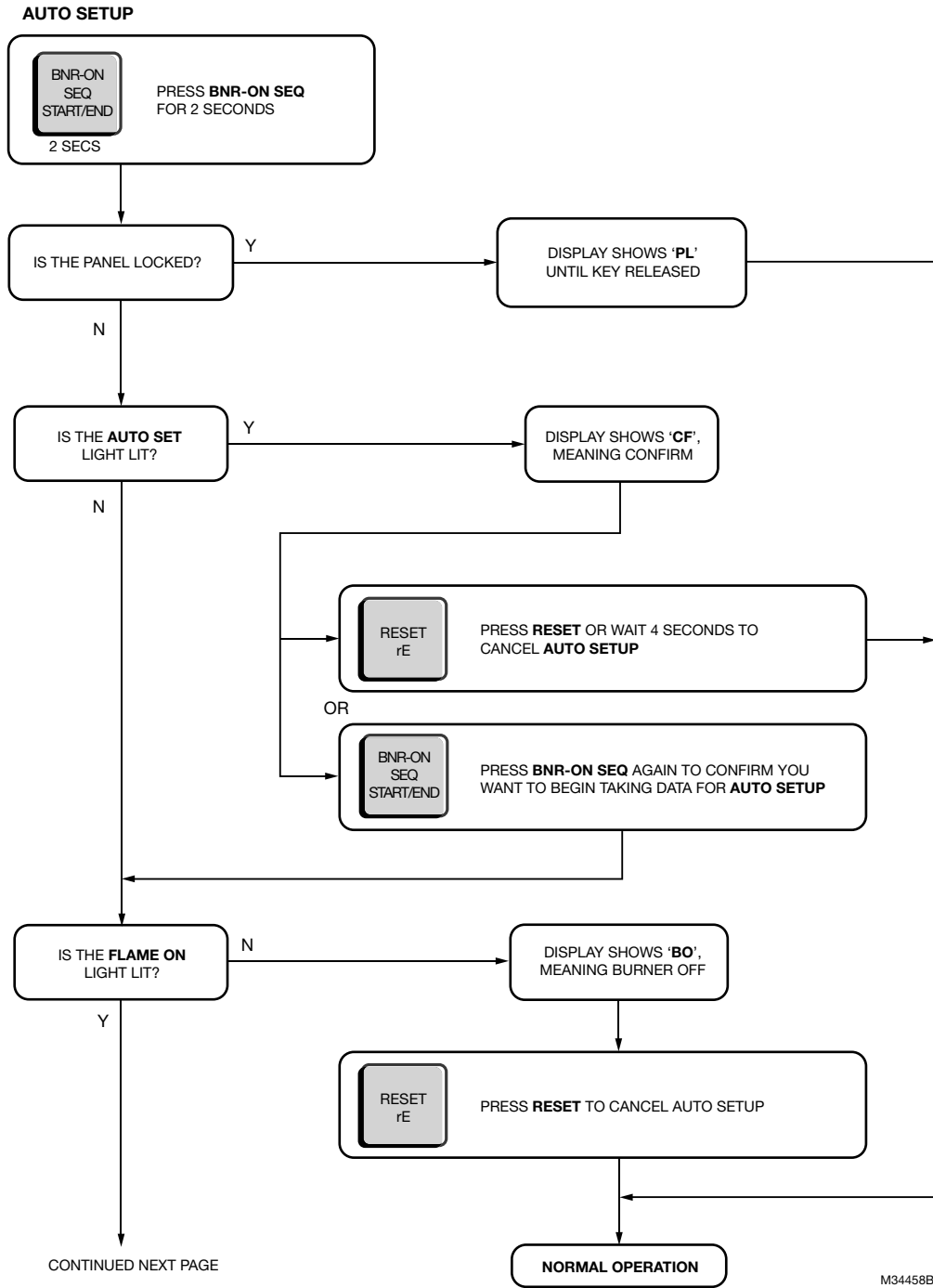
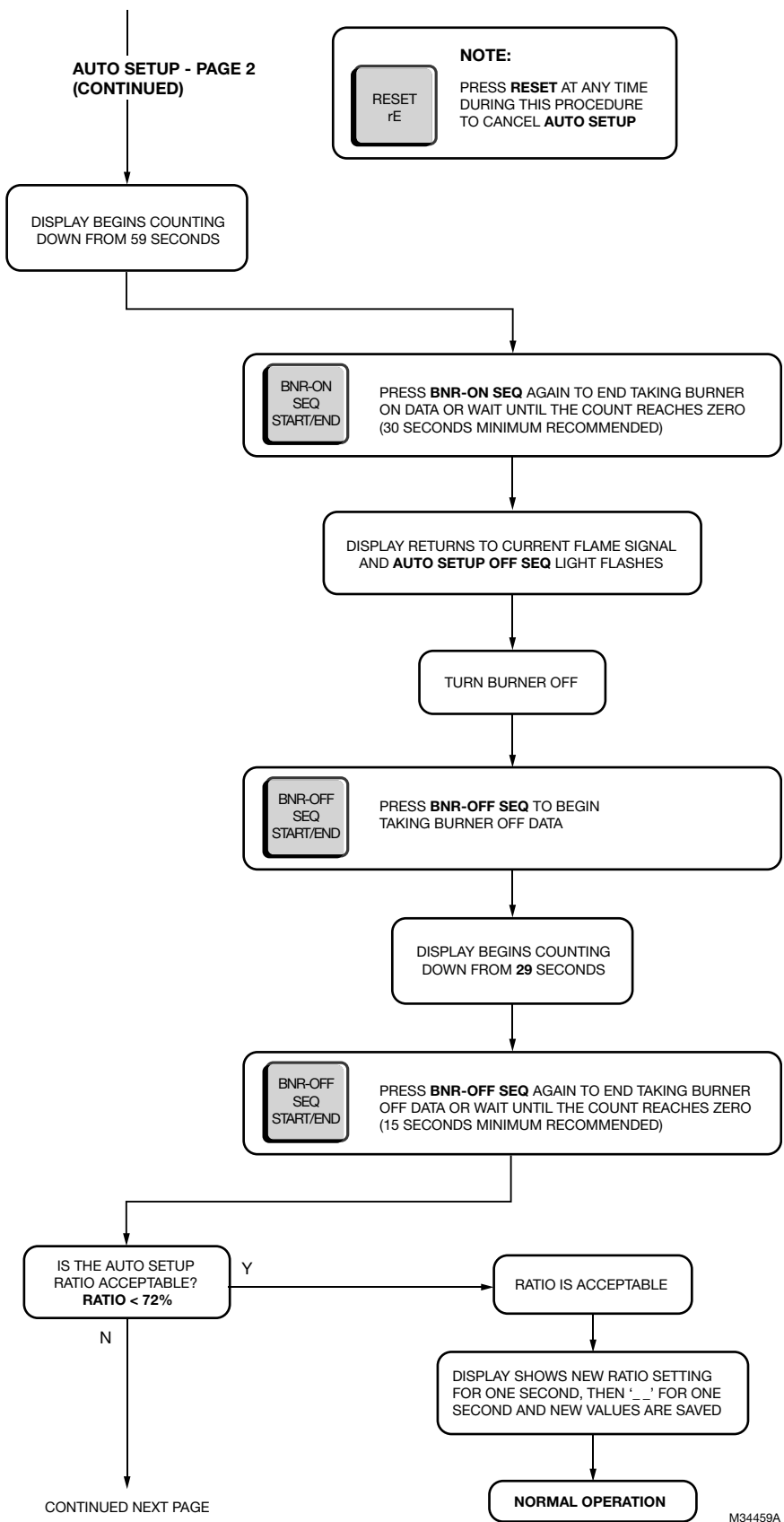

Fig. 20. Flow Chart 2 - Auto Setup Page 1.

M34458B



M34459A

Fig. 21. Flow Chart 3 - Auto Setup Page 2.

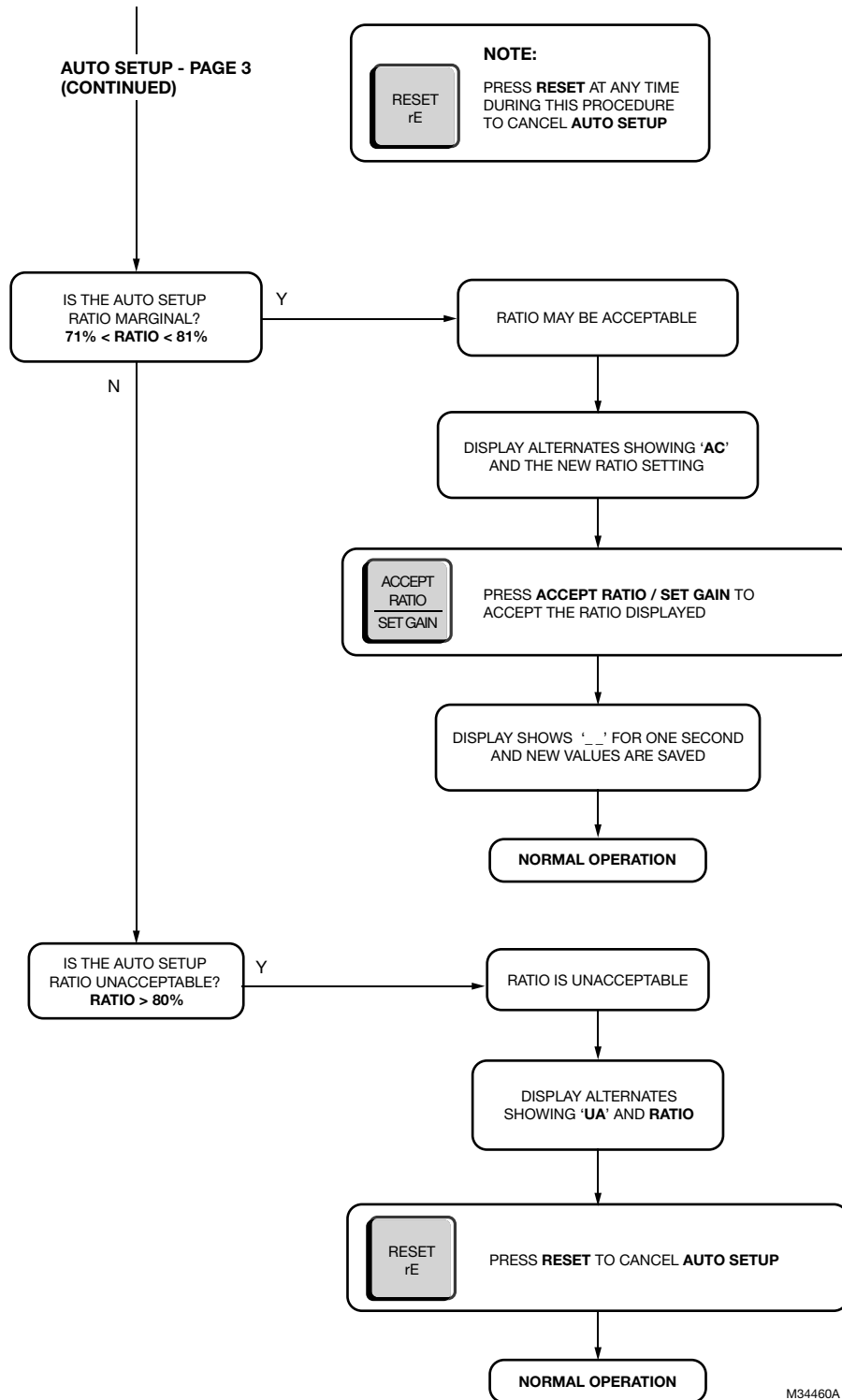

M34460A

Fig. 22. Flow Chart 4: Auto Setup Page 3.

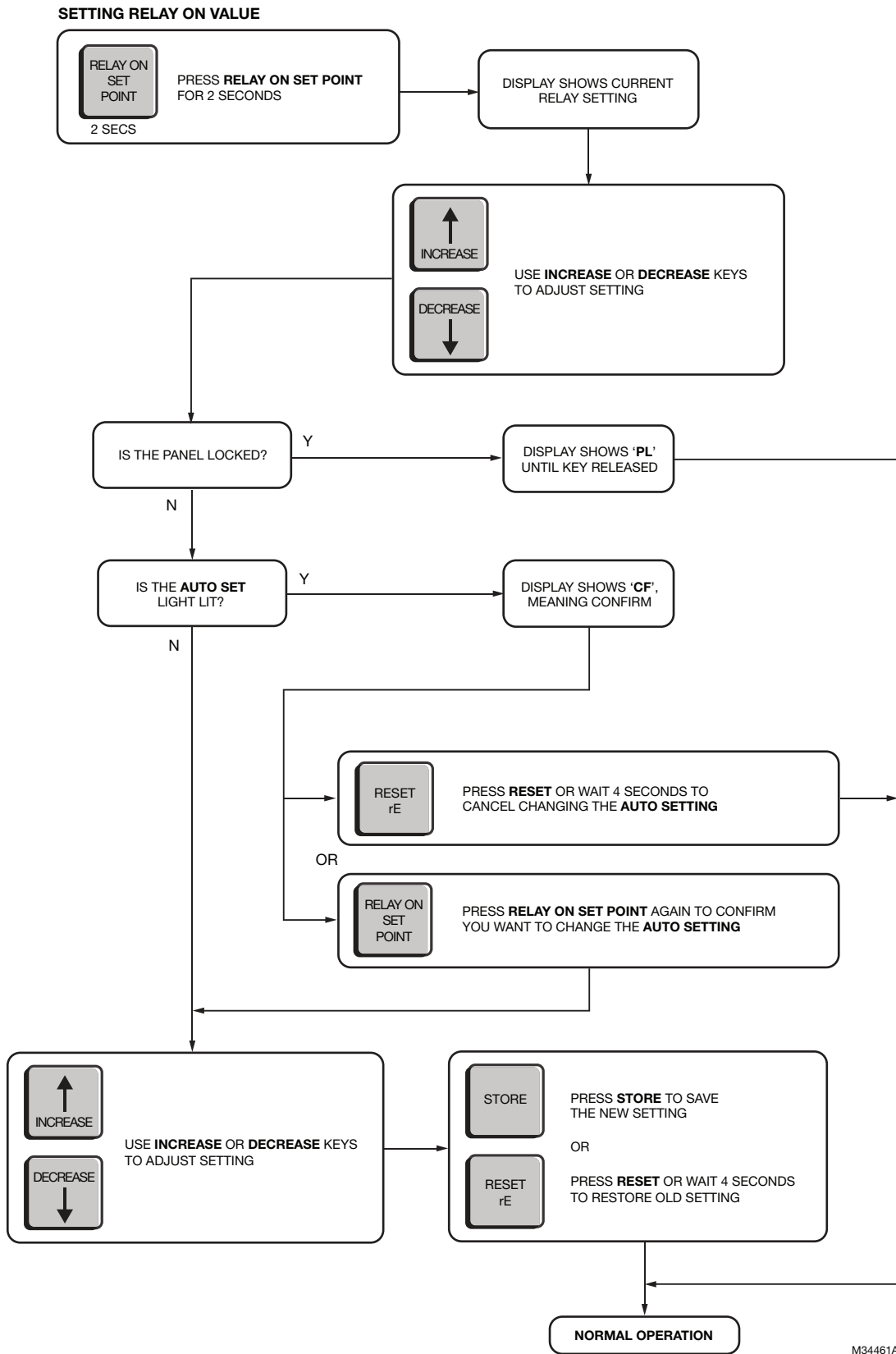

M34461A

Fig. 23. Flow Chart 5: Manual Flame On Setup.

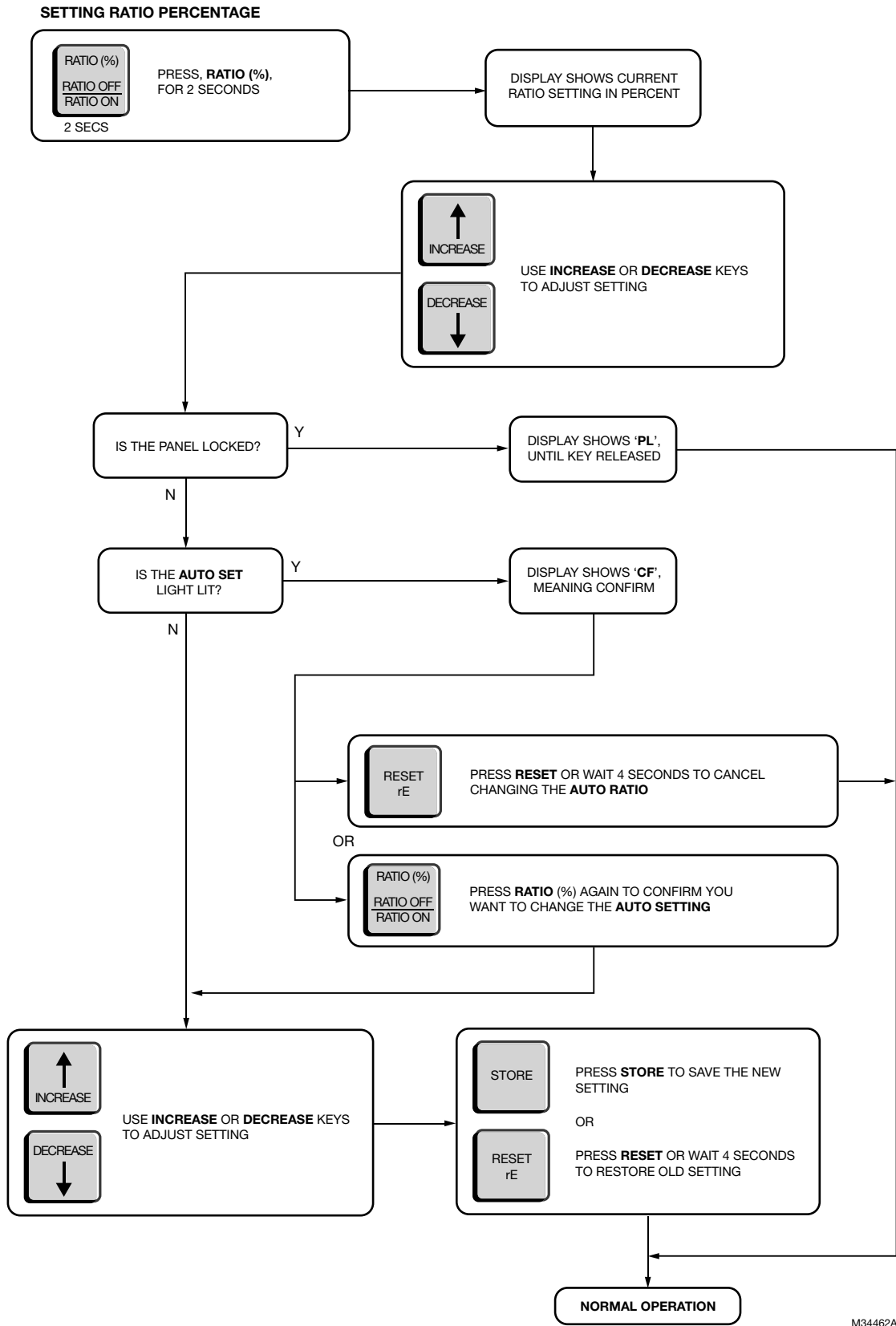

M34462A

Fig. 24. Flow Chart 6: Manual Flame Off Setup.

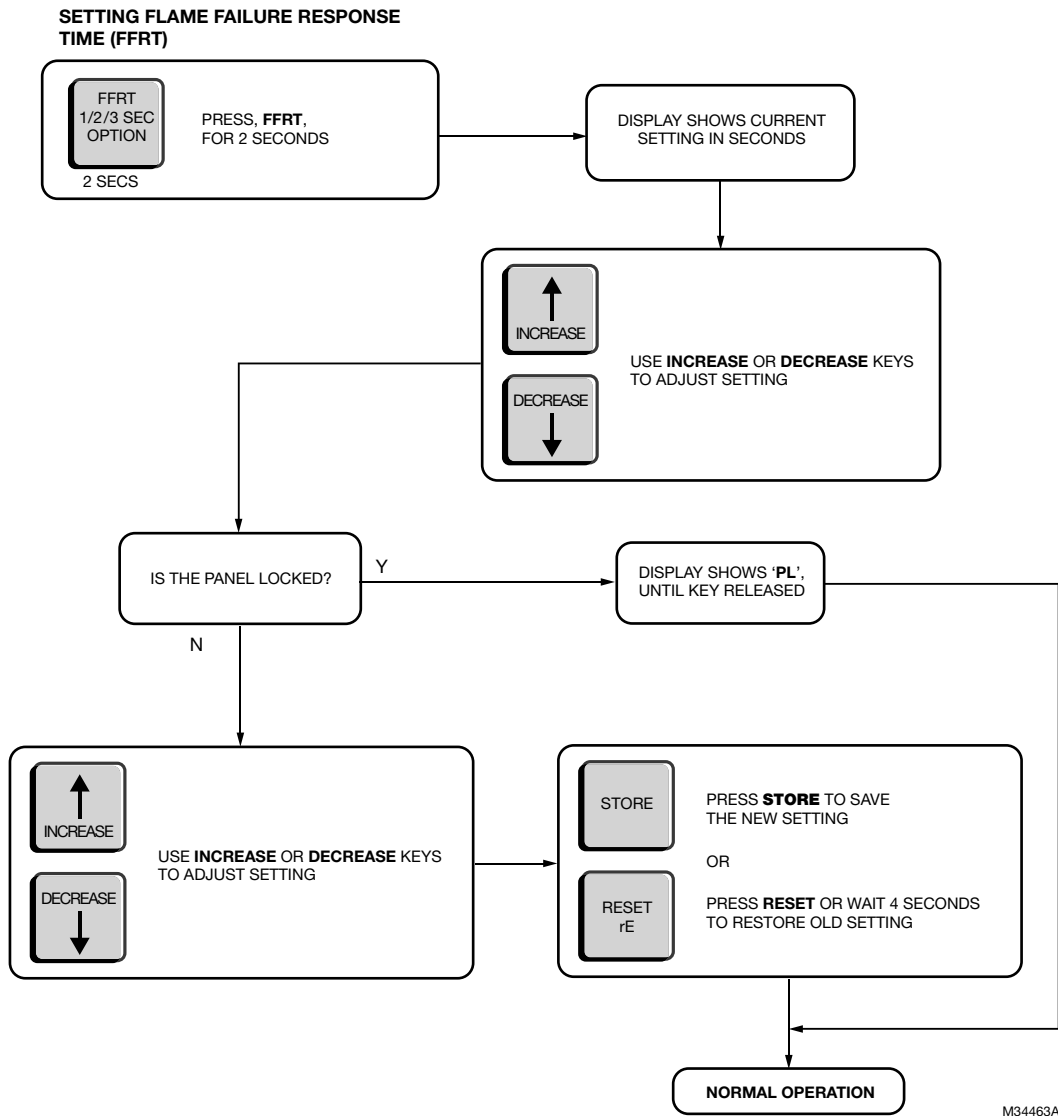

Fig. 25. Flow Chart 7: Flame Failure Response Time (FFRT) Setup.

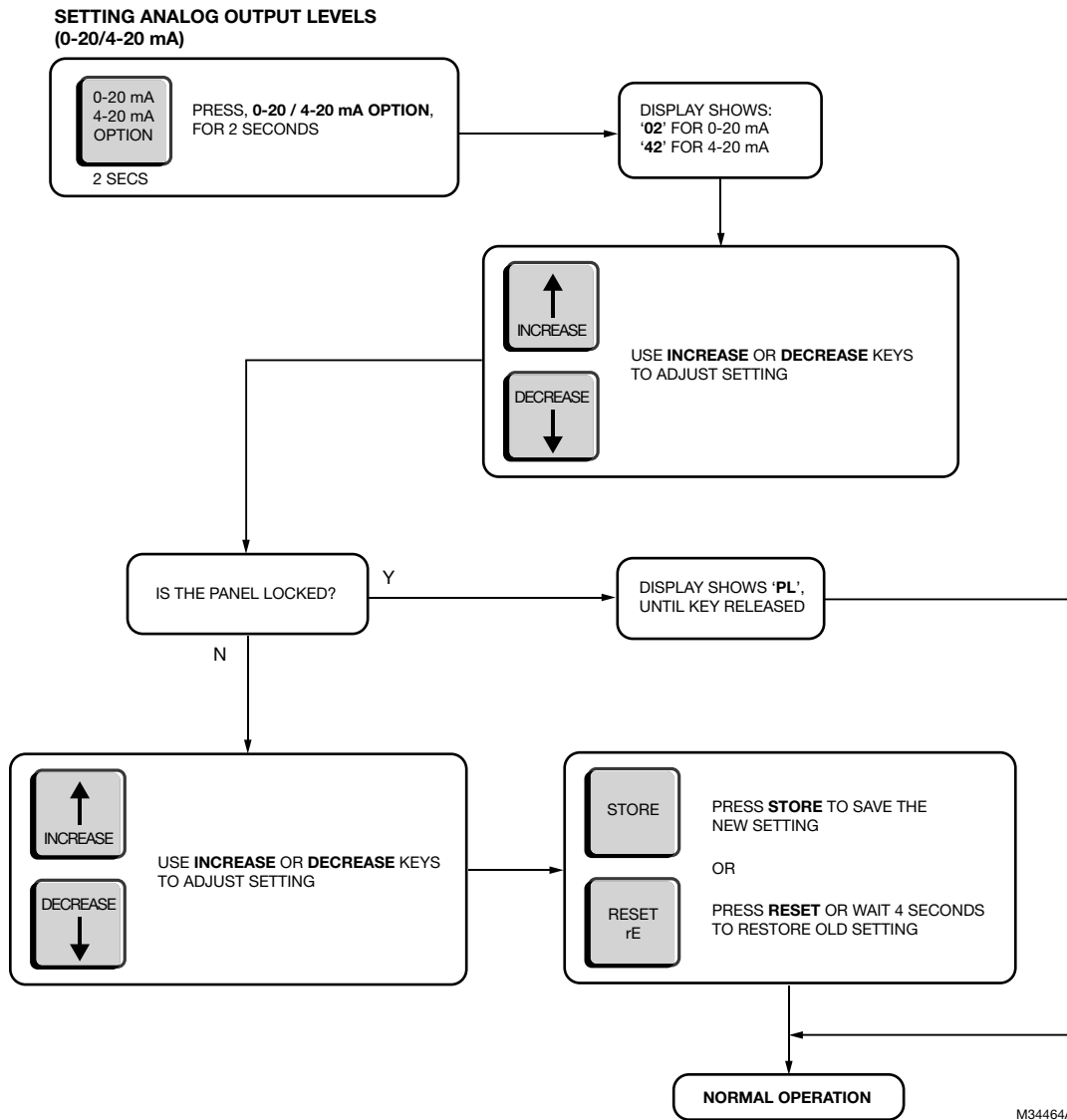

Fig. 26. Flow Chart 8: 0-20/4-20mA Analog Output Setup.

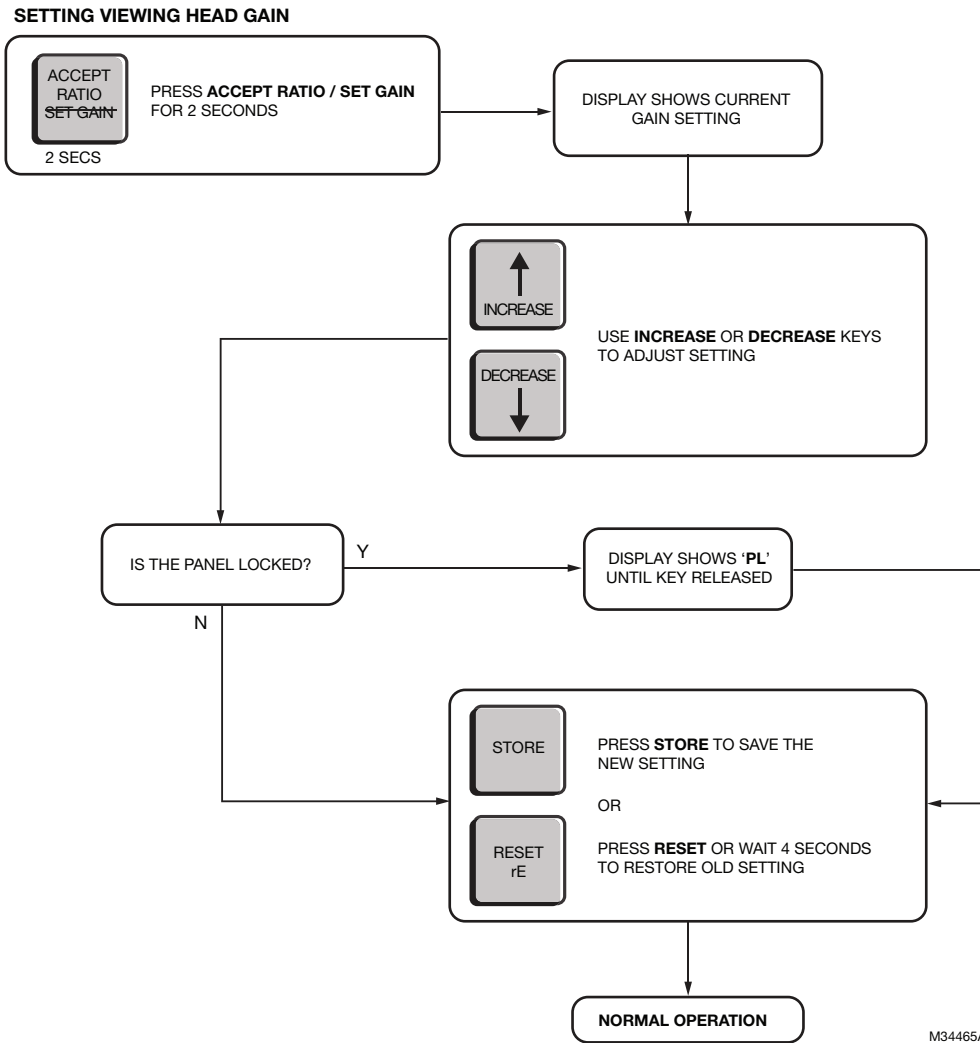

Fig. 27. Flow Chart 9: Viewing Head Gain Setting.

SAFETY MANUAL: 700 SIGNAL PROCESSOR

700ACSP, 700DCSP Product Declaration

FIT FOR USE IN A LOW DEMAND SAFETY APPLICATION.

Models: 700ACSP & 700DCSP

Models	SIL	HFT	SFF	PFD	λ_s	λ_{dd}	λ_{du}
700AC	3	0	>99%	1.79×10^{-4}	1.93×10^{-6}	8.53×10^{-9}	8.20×10^{-9}
700DC	3	0	>99%	1.79×10^{-4}	1.36×10^{-6}	8.53×10^{-9}	8.20×10^{-9}

System Architecture	1oo1
MTTR (Mean Time to Restoration)	8 hours
Proof Test Interval	5 years
Fit for use in	SIL 3 environment

Table 5. Definitions.

Term	Definition
Dangerous Failure	Failure which has the potential to put the safety-related system in a hazardous or fail-to-function state.
Safety-related System	A system that implements the required safety functions required to achieve or maintain a safe state and is intended to achieve on its own or with other systems the necessary safety integrity for the required safety functions.
Safety Function	Defined function, which is performed by a safety-related system with the aim of achieving or maintaining a safe state for the plant, in respect of a specified hazardous event.
Proof Test	Periodic test performed to detect failures in a safety-related system so that, if necessary, the system can be restored to an “as new” condition or as close as practical to this condition.
MTTR (Mean Time to Restoration)	The average duration required for restoration of operations after a failure.
λ_{sd}	Rate of safe detectable failures per one billion hours. For example if $\lambda_{sd} = 3000$, then it is estimated that there will be about 3,000 safe detectable failures during every one billion hours of operation. For $\lambda_{sd} = 3000$, this is about one safe detectable failure every 38 years.
λ_{su}	Rate of safe undetectable failures per one billion hours.
λ_{dd}	Rate of dangerous detectable failures per one billion hours.
λ_{du}	Rate of dangerous undetectable failures per one billion hours.
HFT	Hardware Fault Tolerance
System Architecture	Specific configuration of hardware and software elements in a system.
PFD _{AVG} (Average Probability of Failure on Demand)	Average Probability of Failure on Demand. In this case, regarding the 700 Signal Processor.
FIT (Failures in Time)	A unit of measurement representing one failure per billion hours. 1,000,000,000 hours is approximately 114,155.25 years.

Safety Function of the 700

The safety function of the 700 signal processor consists of a Flame Relay which comprises its safety function and behaves as follows:

The Flame Relay (Normally Open)

- The Flame Relay will be energized when the signal processor is powered and a flame on condition is detected.
- The Flame Relay will be de-energized when the signal processor is powered, a flame of condition is detected, and the FFRT (Flame Failure Response Time) has elapsed.

- The Flame Relay will be de-energized when the signal processor is powered and detects a fault condition.
- The Flame Relay will be de-energized when power to the signal processor is off.

As an added safety feature, the coil of the Flame Relay is wired in series with a second pole of contacts on a Self Check Relay. The Self Check Relay is designed to be closed during normal operation of the signal processor and open during detection of a fault or power down. It is physically impossible for the Flame Relay to be closed if the Self Check Relay is open, unless the contacts of the Flame Relay are welded closed or the contacts of the Self Check Relay are welded closed. To reduce the chance of a false flame on condition, it is recommended that the user wire the Flame and Self Check Relays in series.

Also, as another added safety feature, neither relay can be driven by a simple continuously high or continuously low signal. Each relay must be driven by an alternating signal of the proper frequency and duty cycle from the processor.

700AC or 700DC Signal Processor Proof Test Interval

The Proof test must be conducted every 1 to 5 years. This range is given to allow for the test to be performed during the normally scheduled burner shutdown period. It is the responsibility of the user to perform the proof test in the specified time frame.

The following diagram presents the dependence of the PFD_{AVG} on the proof test interval. The PFD_{AVG} increases as the proof test interval increases.

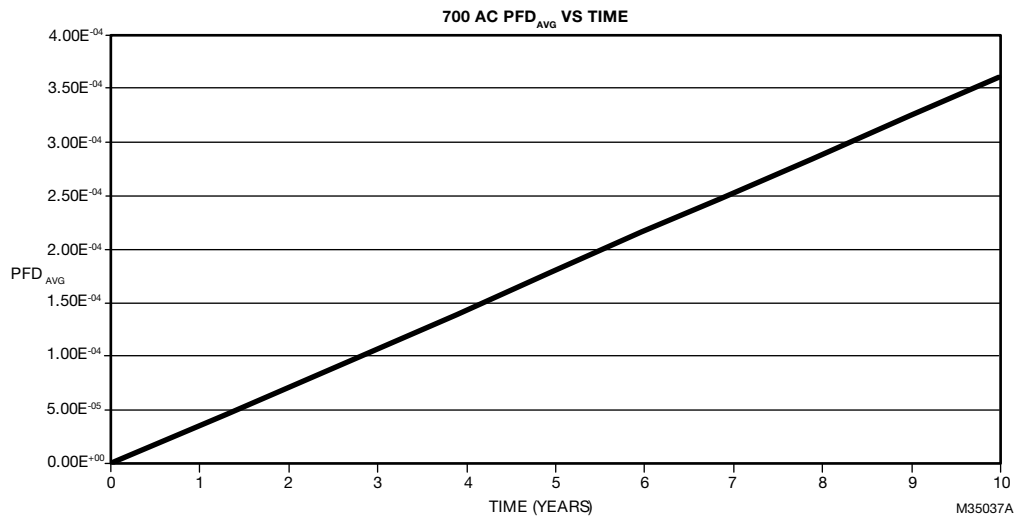

Fig. 28. Dependence of the PFD_{AVG} on the proof test interval for 700AC.

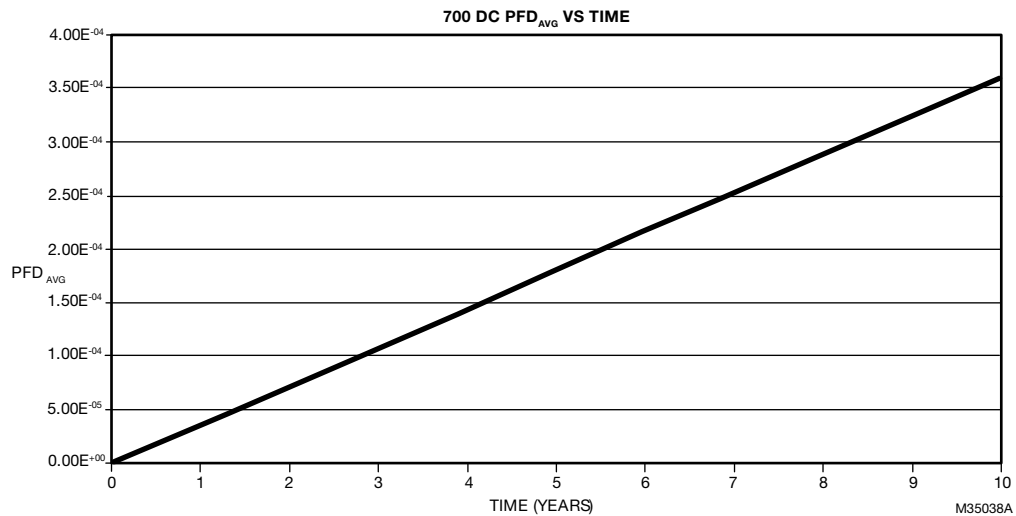

Fig. 29. Dependence of the PFD_{AVG} on the proof test interval for 700DC.

700AC or 700DC Signal Processor Proof Test Procedure

Equipment

- Powered 700AC or 700DC correctly connected to a compatible viewing head.
- Multimeter able to take voltage and resistance measurements.
- For 700AC signal processors, an 85V AC to 265V AC power source.
- For 700DC signal processors, a 22V DC to 26V DC power supply.
- Light source* capable of generating a flame on condition.

* Generally an incandescent bulb will work for IR viewing head sensors and a deep UV light or flame will work for UV viewing head sensors

Setup

1. Ensure the 700AC or 700DC signal processor under test is correctly connected to a compatible viewing head and is fully operational.
2. While performing the proof test, disconnect or disregard the signal processor outputs so that any outputs due to testing do not affect the overall safety system and potentially cause a hazardous situation.
3. Record all previously entered user programmable settings so that you can restore them to their desired values after the proof test.

Tests

1. Remove power to the signal processor and, using a multimeter, ensure continuity between 'SC COM' and 'SC OFF'.
2. Reapply power to the signal processor and, using a multimeter, ensure continuity between 'SC COM' and 'SC ON'.

3. Use a light source to generate a flame on condition and, using a multimeter, ensure continuity between 'RF A COM' and 'RF A ON', and between 'RF B COM' and 'RF B ON'.
4. Remove any light source to generate a flame off condition and, using a multimeter, ensure continuity between 'RF A COM' and 'RF A OFF', and between 'RF B COM' and 'RF B OFF', after the FFRT (Flame Failure Response Time) has elapsed.
5. Measure the current draw of the signal processor with its viewing head attached and ensure it is less than 0.07A RMS for 700AC signal processors and 250mA for 700DC signal processors.
6. Measure the DC voltage between ground 'VH GND' and 'VH +V' going to the viewing head. Ensure it is between 20 and 26 V DC.
7. Change one of the settings of the signal processor and store the changed setting. Remove power to the signal processor for 10 seconds. Restore power to the signal processor and ensure the stored value has remained unchanged.
8. Use your light source to generate flamecounts of between 12 and 22 on the signal processor. Note the flamecount.
 - a. Increase the gain and store the setting. Ensure the flamecount increased.
 - b. Decrease the gain and store the setting. Ensure the flamecount decreased.
9. Restore all original settings as recorded in Setup and reconnect the signal processor to the safety system.

Product Decommissioning

When required, decommissioning of the 700 should be performed in accordance with requirements of the overall safety system.

SAFETY MANUAL: S70X & 80X VIEWING HEAD

S702, S706, S802, AND S806 Product Declaration

FIT FOR USE IN A LOW DEMAND SAFETY APPLICATION.

Models: S702, S702-PF, S706, S706-PF, S802, S806

Models	SIL	HFT	SFF	PFD	λ_s	λ_{dd}	λ_{du}
S702 and S802	3	0	>99%	1.81×10^{-10}	1.70×10^{-7}	2.27×10^{-11}	0
S706 and S806	3	0	>99%	1.51×10^{-5}	1.02×10^{-5}	2.27×10^{-11}	6.90×10^{-10}

System Architecture	1oo1
MTTR (Mean Time to Restoration)	8 hours
Proof Test Interval	5 years
Fit for use in	SIL 3 environment

Table 6. Definitions.

Term	Definition
Dangerous Failure	Failure which has the potential to put the safety-related system in a hazardous or fail-to-function state.
Safety-related System	A system that implements the required safety functions required to achieve or maintain a safe state and is intended to achieve on its own or with other systems the necessary safety integrity for the required safety functions.
Safety Function	Defined function, which is performed by a safety-related system with the aim of achieving or maintaining a safe state for the plant, in respect of a specified hazardous event.
Proof Test	Periodic test performed to detect failures in a safety-related system so that, if necessary, the system can be restored to an “as new” condition or as close as practical to this condition.
MTTR (Mean Time to Restoration)	The average duration required for restoration of operations after a failure.
λ_{sd}	Rate of safe detectable failures per one billion hours. For example if $\lambda_{sd} = 3000$, then it is estimated that there will be about 3,000 safe detectable failures during every one billion hours of operation. For $\lambda_{sd} = 3000$, this is about one safe detectable failure every 38 years.
λ_{su}	Rate of safe undetectable failures per one billion hours.
λ_{dd}	Rate of dangerous detectable failures per one billion hours.
λ_{du}	Rate of dangerous undetectable failures per one billion hours.
HFT	Hardware Fault Tolerance
System Architecture	Specific configuration of hardware and software elements in a system.
PFD _{AVG} (Average Probability of Failure on Demand)	Average Probability of Failure on Demand. In this case, regarding the S702, S706, S802, and S806 viewing heads.
FIT (Failures in Time)	A unit of measurement representing one failure per billion hours. 1,000,000,000 hours is approximately 114,155.25 years.

Safety Function of the S702, S706, S802, and S806

The S702, S706, S802, and S806 viewing heads do not have a safety function. They are used to provide flame intensity information via cables to Signal Processor Models 531AC, 531DC, 532AC, 532DC, 700AC, 700DC, and 800 which use Flame Relays to provide a safety function.

S70X and S80X Viewing Head Proof Test Interval

The proof test must be conducted every 1 to 5 years. This range is given to allow for the test to be performed during the normally scheduled burner shutdown period. It is the responsibility of the user to perform the proof test in the specified time frame.

The following diagrams present the dependence of the PFD_{AVG} on the proof test interval. The PFD_{AVG} increases as the proof test interval increases.

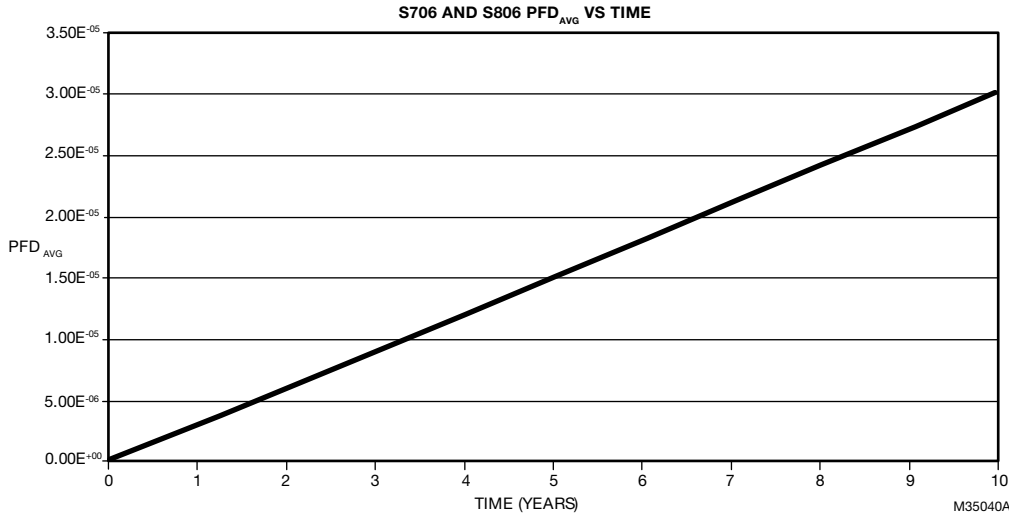

Fig. 30. Dependence of the PFD_{AVG} on the proof test interval for S706 & S806.

S70X and S80X Viewing Head Proof Test Procedure

Equipment

1. 700 or P532 Signal Processor connected to the S702, S706, S802, or S806 viewing head.
2. DC power supply for DC model signal processor and AC power supply for AC model.
3. A source capable of generating UV or IR signals as required.

NOTE: For UV use Honeywell UVsource.
For IR connect incandescent lamp to AC source.

Setup

1. Ensure the S702, S706, S802, or S806 viewing head under test is correctly connected to a compatible signal processor.
2. While performing the proof test, disconnect or disregard the signal processor outputs so that any outputs due to testing do not affect the overall safety system and potentially cause a hazardous situation.
3. Record all previously entered user programmable settings so that you can restore them to their desired values after the proof test.

Tests

NOTE: S702 and S802 viewing heads must be illuminated by an infrared light source. S706 and S806 viewing heads must be illuminated by an ultraviolet light source.

1. Apply power to the signal processor, fully illuminate the viewing head with the light source, and ensure that a flame on condition is indicated by the signal processor.
2. Gradually angle the light source away from the viewing head. Ensure that the count decreases until a flame off condition is indicated by the signal processor.
3. Cover the end of the viewing head with your hand and ensure that the signal processor indicates a flame count of zero.
4. For model 531AC, 531DC, 532AC, and 532DC, signal processors, use your light source to generate a flamecount of between 1200 and 2800, and note the flamecount. For model 700AC, 700DC, and 800 signal processors, use your light source to generate a

flamecount of between 12 and 22, and note the flamecount.

- a. Increase the gain and store the setting. Ensure the flamecount increased.
 - b. Decrease the gain and store the setting. Ensure the flamecount decreased.
5. Restore all original settings as recorded in Setup and reconnect the signal processor to the safety system.

Product Decommissioning

When required, decommissioning of the S70X and S80X viewing heads should be performed in accordance with requirements of the overall safety system.

For More Information

The Honeywell Thermal Solutions family of products includes Honeywell Combustion Safety, Eclipse, Exothermics, Hauck, Kromschröder and Maxon. To learn more about our products, visit ThermalSolutions.honeywell.com or contact your Honeywell Sales Engineer.

Honeywell Process Solutions

Honeywell Thermal Solutions (HTS)
1250 West Sam Houston Parkway
South Houston, TX 77042
ThermalSolutions.honeywell.com

® U.S. Registered Trademark
© 2021 Honeywell International Inc.
66-2069EP-06 M.S. Rev.04-21
Printed in United States

Honeywell