

Series 27000

Horizontal DETECT-A-FIRE® Units
Installation Instructions

12.02.B

FENWAL®

ELECTRICAL RATING

Model No.	Contact Operation on Temperature Rise	Electrical Rating* (Resistive Only)
27020-0	Opens	5.0 Amps 125 VAC
27020-1		0.5 Amps 125 VDC
27021-0	Closes	5.0 Amps 125 VAC
27021-1		0.5 Amps 125 VDC 2.0 Amps 24 VDC 1.0 Amps 48 VDC

*Although incandescent lamps are considered resistive, their inrush current is 10 - 15 times their steady current. Do not exceed ratings.

LOCATION

DETECT-A-FIRE® Units are precision temperature sensors. They must be mounted in an area (normally a ceiling) so that:

1. The detector spacing complies with both system requirements and requirements of the agency having local jurisdiction.
2. The thermal air path to the shell is not obstructed.

Spacing per UL, FM, and UL of Canada are shown in Table 1. Distances given are for between units on smooth ceilings. Distances from partitions or walls are half that shown. To assure that all spacing requirements are met, consult the authority having local jurisdiction.

MOUNTING

Detect-A-Fire units are not position sensitive. Horizontal and vertical detectors refer to the most common mounting configuration for that unit. However, each type can be mounted either horizontally or vertically depending on the application and installation requirements.

Table 1

°F SETTING AND TOLERANCE	COLOR CODING	SPACINGS (in feet)		
		UL	FM	ULC
140 +7°/-8°	Black	50	25	50
160 +7°/-8°	Black	25	25	25
190 +7°/-8°	White	50	25	50
225 +7°/-8°	White	25	25	50
275 ± 10°	Blue	25	25	50
325 ± 10°	Red	50	25	50

DETECT-A-FIRE Horizontal Units are not suitable for use in hazardous locations. Consult Fenwal for units that may be used in these areas.



INSTALLATION

Surface Mount Units:
Series 27020-1 and 27021-1

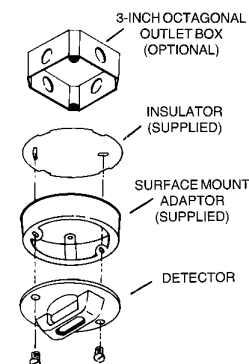

Figure 1

These detectors are provided with a surface mount adaptor which may be mounted on a ceiling or to an outlet box. However, if the adaptor is direct ceiling mounted, **CIRCUIT VOLTAGE MUST BE LIMITED TO 30 VOLTS.**

The Canadian Electrical Code, Part 1, requires that these devices be installed, mounted to an approved outlet box and connected to Class 1 wiring. Surface mount units shall be used only in this manner for Canadian approval.

For direct ceiling mount, proceed as follows:

1. Four knockouts are located on the side of the surface mount adaptor. Remove appropriate knockouts and install supplied rubber grommets.

INSTALLATION (Continued)

2. Mount adaptor to solid ceiling surface through slotted holes in adaptor mounting brackets. Supplied insulator gasket should be placed between ceiling and adaptor. Adaptor may be rotated to position detector.
3. Run system wiring through rubber grommets and connect to terminals on detector per Figure 3 observing applicable electrical codes.
4. Mount detector to adaptor with two #8-32 screws supplied.

For optional outlet box mount, proceed as follows:

1. Bend the mounting brackets on the supplied adaptor to fit standard 4-inch outlet box.
2. Mount adaptor to outlet box through two slotted holes in adaptor mounting brackets. Adaptor may be rotated to position detector.
3. Connect system wiring to terminals on detector per Figure 3 observing applicable electrical codes.
4. Mount detector to adaptor with two #8-32 screws supplied.

Flush Mount Units:

Series 27020-0 and 27021-0

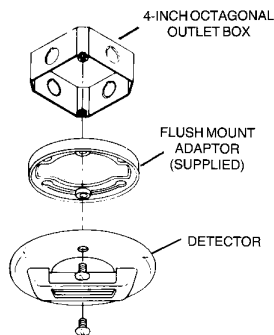

Figure 2

1. It is recommended that a standard 4-inch outlet box be used to mount the detector. Care should be taken that a neat 4-inch diameter hole be cut in ceiling to allow mounting clearance for detector. An oversized or ragged hole may show around the mounted unit.

2. Attach supplied flush mount adaptor to outlet box. Adaptor may be rotated in screw slots to position detectors as desired.
3. Connect system wiring to terminals on detector per Figure 3 observing applicable electrical codes.
4. Mount detector to adaptor with two #8-32 screws supplied.

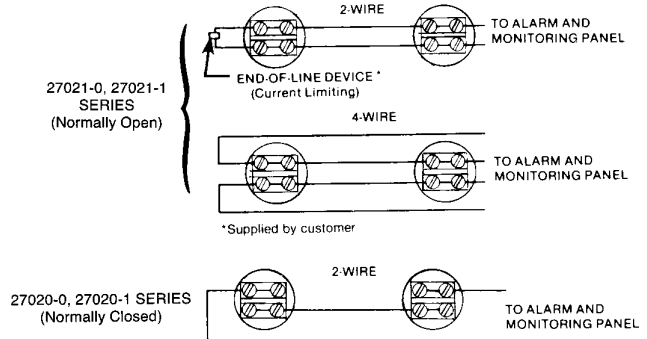

Figure 3: System Wiring

⚠ WARNINGS

1. In order to function properly, the shell of the unit must remain free from paint, grease, oil, etc. Should such a build up occur, do not, **under any circumstances**, attempt to remove it. Replace the unit.
2. Detectors mounted in an area subject to physical abuse or damage, other than above, must be suitably protected without obstructing the thermal air path to the unit.
3. Do not install the unit where the shell would be physically damaged by sand, grain, rocks, etc.
4. Any detector that has been abused or damaged must be replaced.
5. Consult the factory for special precautions necessary for outdoor use.

ANY OF THE ABOVE COULD CHANGE THE FACTORY TEMPERATURE SETTING, WHICH MAY RESULT IN PROPERTY DAMAGE AND/OR PERSONAL INJURY OR DEATH.

IT IS POSSIBLE FOR A UNIT TO HAVE BEEN ABUSED OR DAMAGED AND NOT DISPLAY ANY OUTWARD INDICATION OF THE DAMAGE. ALL UNITS SHOULD BE TESTED PERIODICALLY IN ACCORDANCE WITH NATIONAL FIRE PROTECTION ASSOCIATION REQUIREMENTS (72E) OR THE AGENCY HAVING LOCAL JURISDICTION.

This literature is provided for informational purposes only. KIDDE-FENWAL, INC. assumes no responsibility for the product's suitability for a particular application. The product must be properly applied to perform as described herein.

If you need more information on this product, or if you have a question, contact KIDDE-FENWAL, INC., Ashland, MA 01721. (508) 881-2000.

FENWAL®

KIDDE-FENWAL, INC.

400 MAIN STREET, ASHLAND, MA 01721

TEL: (508) 881-2000 FAX: (508) 881-6729