

# WK SERIES

## 2-wire TRANSMITTER

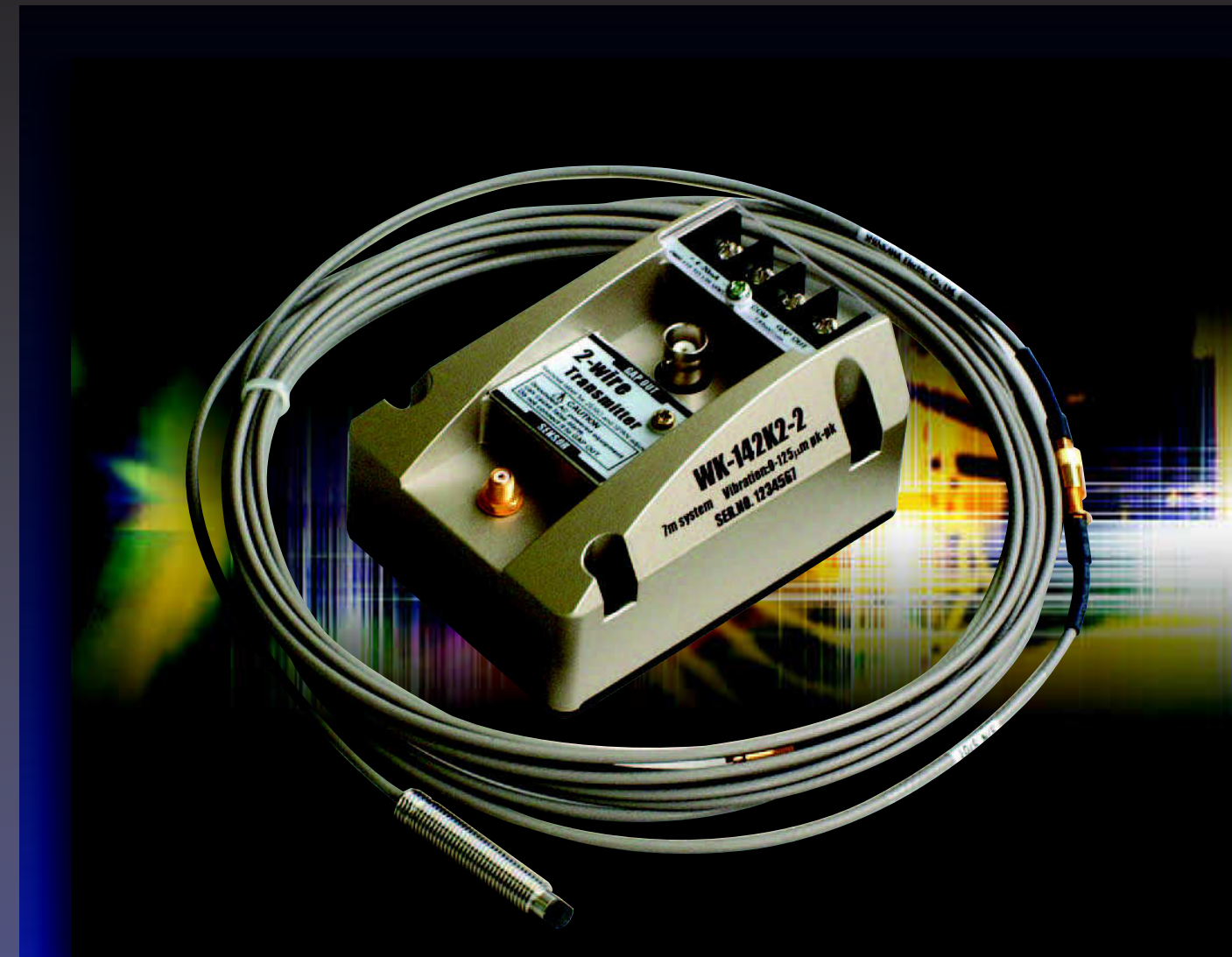

**Monitors or signal converters are unnecessary.**

**Electric current output makes long wiring possible.**

**Direct connection to control instruments.**

**The ideal system for monitoring small compressor vibrations.**



Contact to

Published in Mar. 2009

### SHINKAWA Electric Co., Ltd.

3rd Fl. Shin-kojimachi Bldg.3-3 Kojimachi 4-chome, Chiyoda-ku,Tokyo 102-0083, Japan  
Phone : 81-3-3263-4411 Fax : 81-3-3262-2171  
WEB : <http://www.shinkawa.co.jp/>

### SEC of America Inc.

4355 Ferguson Drive Ste. 215, Cincinnati, Ohio 45245, USA  
Phone: 1-513-453-4560 Fax: 1-513-297-9003  
email: [info@sec-america.com](mailto:info@sec-america.com)  
WEB: <http://www.sec-america.com>

### SHINKAWA Sensor Technology, Inc.

4-22 Yoshikawa-kogyodanchi, Higashihiroshima 739-0153, Japan  
Phone : 81-82-429-1118 Fax : 81-82-429-0804  
WEB : <http://www.sst-shinkawa.co.jp>

\* Specifications, outline drawings and other written information can be changed without notice.

# SIMPLE WIRING - 2-WIRE TRANSMITTER

The WK series transmitter is an eddy-current type transmitter that incorporates vibration converter features, supplying the power and transmitting the signal with a 2-wire current loop. The WK system reduces equipment and wiring costs. Two kinds of transmitters are available - the WK-142K for shaft vibration, and the WK-142T for thrust position.



**Monitors or vibration converters are unnecessary.**  
**Electric current output makes long wiring possible.**  
**Direct connection to control instruments.**  
**The ideal system for monitoring small compressor vibrations.**

## Example of SYSTEM CONFIGURATION

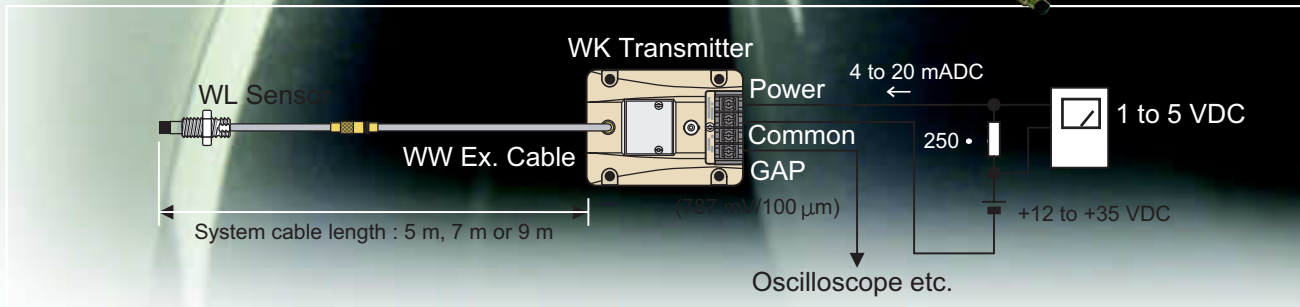

## Outline Drawing

## Specifications

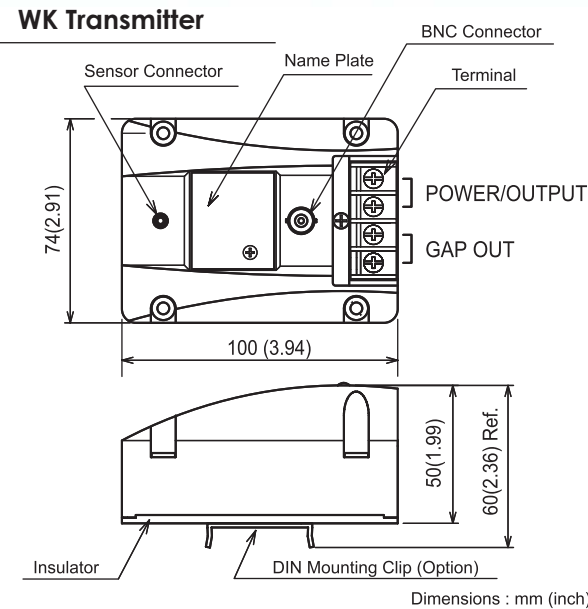

	WK-142K	WK-142T
<b>Current Output</b>	0 to 100 $\mu$ m pk-pk, 0 to 125 $\mu$ m pk-pk, 0 to 200 $\mu$ m pk-pk, 0 to 250 $\mu$ m pk-pk, 0 to 400 $\mu$ m pk-pk	-0.6 to 0 to +0.6 mm, -0.635 to 0 to +0.635 mm
<b>4 to 20mA Output Conversion Accuracy</b>	• 4.5% of full scale range (from test signal input pin to current output)	• 4.0% of full scale range (from test signal input pin to current output)
<b>Max. Load Resistance</b>	43.5 • (Vps-12) • (Vps=Power supply voltage)	
<b>Calibration Material</b>	JIS SCM440 flat (AISI 4140 equivalent)	
<b>Linear Range*</b>	1.4 mm (Gap : 0.3 to 1.7 mm)	
<b>Scale Factor*</b>	7.87 mV/ $\mu$ m	
<b>Scale Factor Error*</b>	5 m, 7 m system : 7.87 mV/ $\mu$ m • 6.5% typ. (including interchangeability errors) 9m system : 7.87mV/ $\mu$ m • 4.0% typ. (including interchangeability errors) Step : 200 $\mu$ m, Target : 30 mm dia.	
<b>Output Impedance*</b>	10 k • (it is calibrated load impedance at 10 M • )	
<b>Frequency Response*</b>	5 Hz to 6,000 Hz (• 0 dB, • 8 dB) at 900 $\mu$ m Gap	
<b>Operating Temperature Range</b>	Transmitter : 0 to 70 • Sensor & Extension cable : • 84 to • 177 • (Connector : Max.125 • )	
<b>Relative Humidity</b>	95% RH (non-condensing)	
<b>Power Supply Voltage</b>	12 to 35 VDC	
<b>System Cable Length</b>	5 m, 7 m or 9 m	5 m, 7 m

\* The above specifications apply at 25 • with 24 VDC power supply and SCM440 (AISI 4140 equivalent) steel flat target.

## Model Code

For Shaft Vibration

WK-142K □ - □ /NB1 /DNC /CEM

System Cable Length	Output Range	Non-incendive	With DIN Mounting Clips	CE Marking
1	5 m	1	0 to 100 $\mu$ m pk-pk	1 CSA : Class I Div.2 Gr. A,B,C,D ATEX : EEx nA II T6
2	7 m	2	0 to 125 $\mu$ m pk-pk	
5	9 m	3	0 to 200 $\mu$ m pk-pk	
		4	0 to 250 $\mu$ m pk-pk	
		5	0 to 400 $\mu$ m pk-pk	

For Thrust Position

WK-142T □ - □ /NB1 /DNC /CEM

System Cable Length	Output Range	Non-incendive	With DIN Mounting Clips	CE Marking
1	5m	1	-0.6 to 0 to +0.6 mm	1 CSA : Class I Div.2 Gr. A,B,C,D ATEX : EEx nA II T6
2	7m	2	-0.635 to 0 to +0.635 mm (-25 to 0 to +25 mils)	

## Outline Drawing and Model Code

WL Sensor

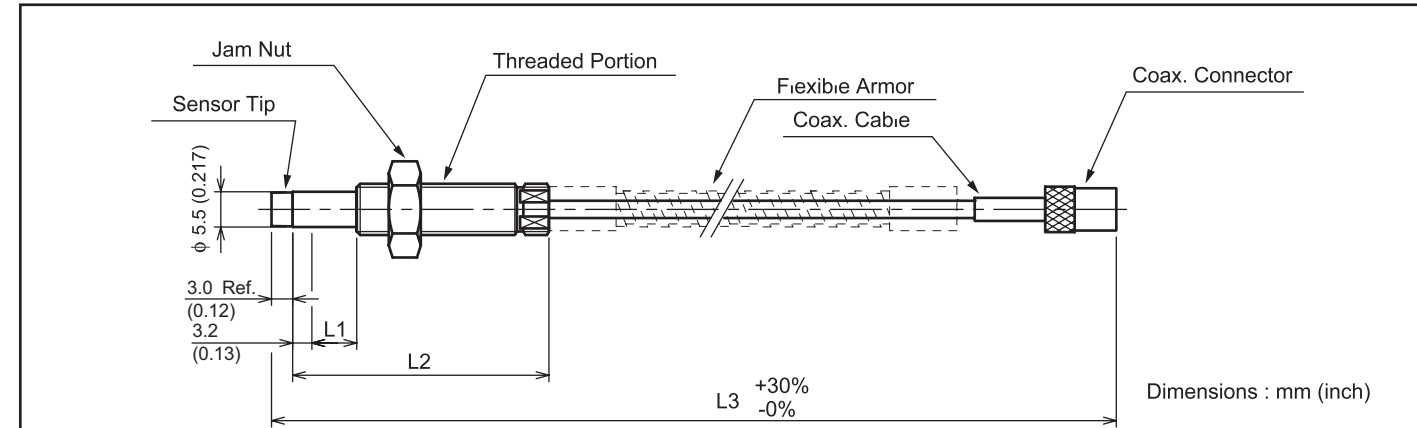

WL-142K05 □ - □ □ □ □ □ □ /NB1

	Armor	Threaded Size	Unthreaded length* (L1)	Case length* (L2)	Cable length (L3)	Non-incendive	
A	With (Without Fluoro resin coating)	M1	M8 x 1	10 mm step, 0 to 230 mm e.g.) 06 = 60 mm	10 mm step, 20 to 250mm e.g.) 25 = 250 mm	1	1 CSA : Class I Div.2 Gr. A,B,C,D ATEX : EEx nA II T6
T	With (With Fluoro resin coating)	M2	M10 x 1	L1 • •L2 - 20 mm		2	
L	Without	U1	1/4-28 UNF-2A	0.1 inch step, 0 to 9.2 inch e.g.) 04 = 0.4 inch	0.1 inch step, 0.8 to 9.9 inch e.g.) 35 = 3.5 inch	3	
		U2	3/8-24 UNF-2A	L1 • •L2 - 0.7 inch		4	

## WW Extension Cable

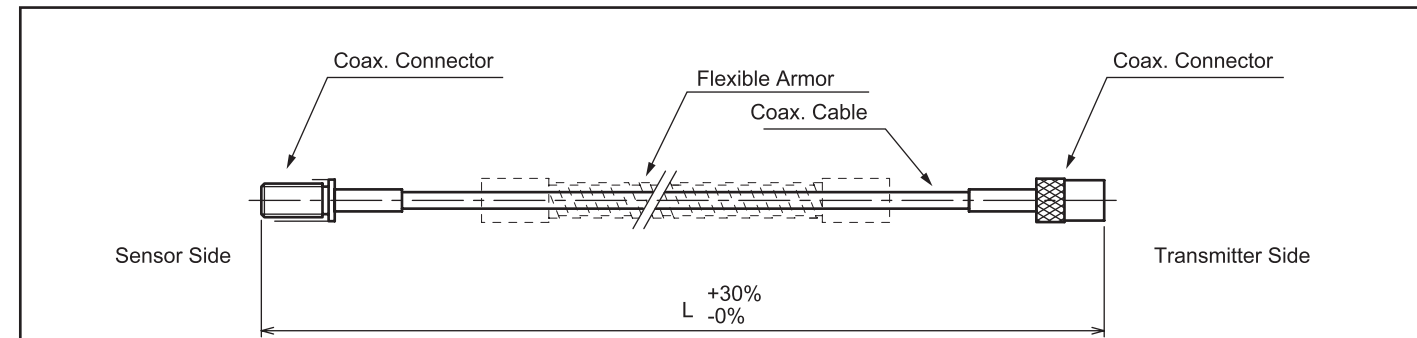

WW-142K □ - □ /NB1

	Armor	Extension Cable length	Non-incendive
A	With (Without Fluoro resin coating)	1	1 CSA : Class I Div.2 Gr. A,B,C,D ATEX : EEx nA II T6
T	With (With Fluoro resin coating)	2	
L	Without	3	
		4	
		5	
		6	