

Overview

GE Security hazardous location AdaptaBeacon Strobe Lights are designed for installation in hazardous location environments. Rigid specifications and state-of-the-art technology provide for high visual output and low maintenance.

Agency Approvals

- **cUL listed for:**
 - Class I, Division 2, Groups A, B, C and D
 - Class II, Division 1, Groups E, F and G
 - Class III Divisions 1 and 2
- **NEMA Type 3R and 4 rated**

Ordering Information

Catalog Number	Mounting	Electrical Rating	Optional Dome Guard
107DV2PST(+)-N5	Pendant	120VAC* 0.1 Amp	EDVPGU1
107DV2PST(+)-R5		240VAC* 0.05 Amp	
107DV2PST(+)-EK		12-48 Vdc, 1.2 Amp	
107DV2PST(+)-S1		250 Vdc, 0.1 Amp	
107DV2BST(+)-N5	Bracket	120VAC* 0.1 Amp	EDVPGU1
107DV2BST(+)-R5		240VAC* 0.05 Amp	
107DV2BST(+)-EK		12-48 Vdc, 1.2 Amp	
107DV2BST(+)-S1		250 Vdc, 0.1 Amp	
107DV2CST(+)-N5	Ceiling Box	120VAC* 0.1 Amp	EDVPGU1
107DV2CST(+)-R5		240VAC* 0.05 Amp	
107DV2CST(+)-EK		12-48 Vdc, 1.2 Amp	
107DV2CST(+)-S1		250 Vdc, 0.1 Amp	

(+) Specify colour: R=Red, A=Amber, B=Blue, G=Green, C=Clear, M=Magenta
* 50/60 Hz

Standard Features

- **Pendant, wall bracket and ceiling mount models**
- **Weatherproof**
- **High impact glass dome**
- **Dome guard (optional)**

Specifications

- **65 flashes per minute**
- **Polycarbonate inner lenses in six colours: red, amber, blue, green, magenta, and clear**

Applications

Typical industrial and commercial applications include: food processing plants, refineries, mines, tankers, laboratories, sewage treatment plants, water and filtration plants, and chemical plants.

Installation and Mounting

Designed for hazardous location installation on 3/4" (19mm) conduit, or 4" (102mm) square box, with the dome facing down.

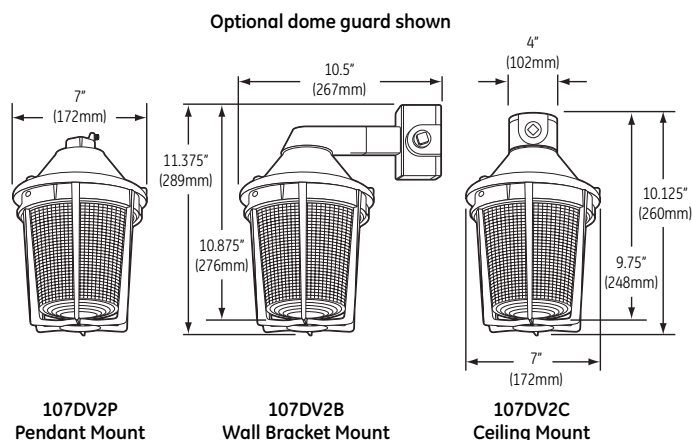

Division 2 AdaptaBeacon® Strobe Lights

107DV2ST Series

