

Senscient ELDS™ OPGD Series 1000 Ammonia

Fulfilling the promise of open path gas detection (OPGD)

About Senscient ELDS OPGD

ELDS™ is a patented, new open path gas detection (OPGD) technology from Senscient. The innovative Enhanced Laser Diode Spectroscopy (ELDS) detection technology featured in our ELDS Series of open path gas detectors truly fulfills the promise of fit-and-forget open path gas detection...

- **Reliable detection of both toxic & flammable gases.**
- **Industry's first false-alarm free Open Path Gas Detector.** ELDS detection is molecular species specific, eliminating false alarms from common atmospheric or non-hazardous gases that plague traditional OPGD (or any NDIR or LDS technology) systems.
- **FIRST and ONLY laser open path combustible gas detector to meet current industry Safety Standards.**
- **FIRST and ONLY gas detector with SimuGas™, an electronic, remote functionality check.**
- **3 orders of magnitude greater sensitivity for combustible gases versus conventional NDIR-based detectors.**
- **Up to 60% reduction in gas detection project CapEx and OpEx, with true Fit-&-Forget functionality.**
- **Backed by a network of industry-leading gas detection solutions providers.**



Senscient ELDS OPGD Series 1000 Ammonia Detector Features / Benefits:

- Reliable, open path detection of ammonia at levels low enough to provide early warning for leakage of this highly flammable gas. Detection Limits for ammonia leak detection are orders of magnitude lower than any other OPGD product.
- Specific detection of Ammonia without any cross interference from any other gases virtually eliminates false alarms.
- True ease-of-installation, with vibration and misalignment tolerant optics.
- SimuGas™ feature provides ability to accomplish on-demand, remote functionality testing right from the control room or PLC!
- 316L Stainless steel construction designed to provide maximum corrosion resistance for installation in sea and land-based Hazardous Area facilities.

Applications:

Onshore Petrochemical, Pharmaceutical, Agricultural, Industrial Refrigerants and mid-industrial facilities.

Theory of Operation:

Using a separate transmitter and receiver configuration, Senscient ELDS Series 1000 Ammonia OPGD systems can detect and measure ammonia over distances between 5 and 120 m. The ELDS technique measures the Harmonic Fingerprint introduced onto the transmitter's laser beam(s) by absorption by any target gas in the monitored path.



Senscient ELDS™ OPGD Series 1000 Ammonia

Fulfilling the promise of open path gas detection (OPGD)

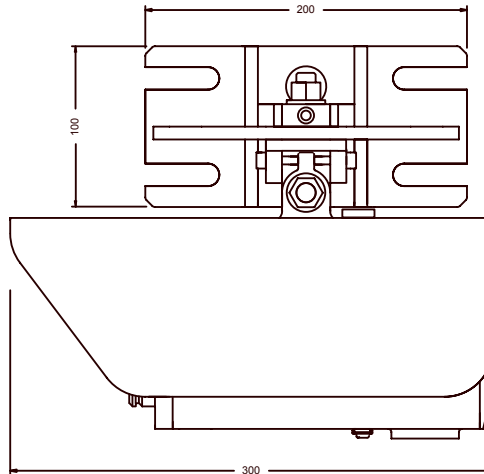
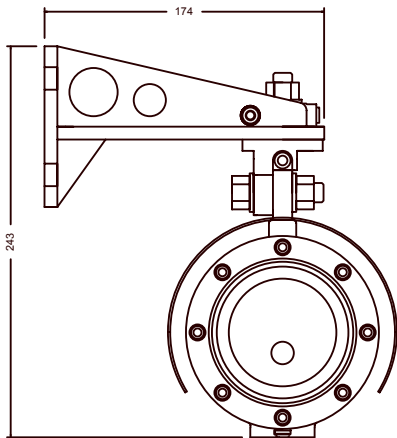

Specifications:

Gas: Ammonia
 Ranges: 0-1,000 ppm.m
 Path-Length: 5-40 m = Short = S
 40-120 m = Medium = M

Performance:

Response Time: T90 <= 3 seconds
 Resolution: 0.5% FSD
 Repeatability: <= +/- 2% FSD
 Linearity: <= +/- 2% FSD
 Zero Drift: <= +/- 1% FSD
 Span Drift: <= +/- 2% FSD
 Min. Alarm Threshold: 10% FSD

Environmental:

Ingress Protection: IP66/67 (Baseefa) Type 4/6 (CSA)
 Enclosure Material: 316L stainless steel
 Operating Temperature: -40° C to +60° C
 Humidity: 0 – 100% RH (non-condensing)
 Vibration: 10 -150 Hz, 2g
 EMC: EN50270
 Meteorological Visibility: Operates @ Met. Visibility > = Path-Length

Certification / Approvals:

CSA North America Approval to CSA and UL Standards

Class 1 Div 1 Groups B C & D T5
 Class II/III, Div 1, Groups E F & G T5
 Ex d IIB + H2 T5
 Class I, Zone 1, AEx d IIB + H2 T5
 Tamb = -40° C to +60° C
 Entry: ¾" NPT

BASEEFA ATEX:

II 2 G Ex d IIB + H2 T5
 II 2 D Ex tD A21 T100° C IP66/67
 Tamb = -40° C to +60° C
 Entry: M25



GOST-K & GOST-R: Pending

Safety Integrity - Suitable for use in SIL2 Safety Systems per IEC 61508

Electrical:

Operating Voltage: +24 V nominal, operates correctly for supply voltages between +18 V and +32 V
 Power Consumption: TX = 12W (max), RX = 10W (max)
 Output (Analog): 4-20 mA (2 wire, isolated)
 Configurable for single wire, sink or source
 Capable of driving 0-600 Ohm load

Low Signal: 3 mA (configurable 1 mA to 4 mA)
 Beam Block: 2.5 mA (configurable 0 mA to 3.5 mA)
 Inhibit: 2 mA (configurable 1 mA to 4 mA)
 Fault: 0 mA (configurable 0mA to 1mA)
 Output (Digital): HART and MODBUS RTU communication protocols pending

Mechanical:

Size: TX/RX 140 mm dia. x 300 mm
 Weight: TX/RX 12 kg each
 Mounting: TX & RX units supplied fitted with a mounting bracket which incorporates holes / slots for fixing on flat surfaces or metal poles (4" to 6" diameter - requires U bolts).

Optical:

The unit will operate correctly, without spurious readings or faults during conditions of misalignment or partial obscuration.

Alignment: +/- 0.5°
 Obscuration: > 95%
 Heated Optics: The window-lenses of the TX and RX units are heated.

Calibration, Testing & Maintenance:

Calibration: Units supplied factory calibrated for the specified target gas or gases. Units should not require re-calibration in service.

Part Number:

Senscient ELDS V-GGGG-C

Where:

V = S = Short Range
 = M = Medium Range

GGGG = 1080 = 0-1,000 ppm.m

C = 3 = BASEEFA ATEX
 = 4 = CSA North America Approval to CSA and UL Standards

E.g. Senscient ELDS M-1080-3 is a medium range ELDS OPGD calibrated for 0-1,000 ppm.m Ammonia with BASEEFA ATEX approval.

Distributed by:



Senscient, Inc. • Phone: 1-713-953-8663, or toll-free 1-877-eSIMUGAS (1-877-374-6842)

Email: info@senscient.com • www.Senscient.com

2951 Marina Bay Drive Suite 130-307 • League City, Texas, USA 77573-2785